



**TÉCNICO**  
LISBOA



## **Design and Assembly of a Ground Control Station for Long Range and Long Endurance UAVs**

**Nelson Teixeira Cavaco**

Thesis to obtain the Master of Science Degree in

### **Aerospace Engineering**

Supervisor: Prof. André Calado Marta

#### **Examination Committee**

Chairperson: Paulo Jorge Coelho Ramalho Oliveira

Supervisor: Prof. André Calado Marta

Member of the Committee: Pedro Vieira Gamboa

**November 2022**



To my family and friends.



## Acknowledgments

If I ever made so far is due to all the people I am going to thank next.

My teachers that since the high school pushed me forward to reach my limits and improve my capabilities. Because of that they have my gratitude.

My friends are also part of this! Some gave me joy, some motivated me to fly higher, others told me to get the work done, acting like my parents wich I hate so bad. In a nutshell, every single one of them contributed in their way to the success of this seven year mission and I can only thank them for this.

A very special thank you for the RED Team. Without them and their friendship, support and all the joy I could not truly fulfill my dreams. Thank you for all the effort and ideas you came up with in order to help me execute this work.

Another very special thank you goes to Professor André Calado Marta, for their support, very professional and encouragement during this last year.

Finally, all my gratitude goes to my family, to my mother and father that had always supported me financially and educated me as the man I am today.



## Resumo

O aumento de aplicações para veículos aéreos não tripulados requer sistemas robustos e de confiança que consigam satisfazer um largo número de requisitos para uma ampla variedade de missões. Ter à disposição uma estação de controlo que assegure segurança, fácil configuração, adaptabilidade, fácil de tomar decisões rápidas durante a missão é alguns dos aspectos importantes para uma missão de qualquer sistema aéreo não tripulado. Assim sendo, o projeto e construção de uma estação de controlo para missões de longa duração e longo alcance é apresentada. Os requisitos para a missão são derivados de missões de vigilância civil, vigilância florestal, marítima ou fronteiriça por exemplo. Nesta dissertação são apresentados os aspectos importantes do projeto e da sua construção bem como uma descrição de cada componente e sistema e a maneira como eles funcionam entre si para compor esta estação de controlo em particular. É demonstrada a viabilidade de se construir uma estação de controlo de baixo custo móvel que desempenhe missões até 8h de duração e com um alcance até 100 km.

**Palavras-chave:** Estação de Controlo Terrestre, Veiculo Aéreo Não Tripulado, Sistema Aéreo Não Tripulado, Longa Duração, Longo Alcance.





## **Abstract**

The increasing number of applications for unmanned aerial vehicles demands reliable systems that can meet the requirements of a wide range of missions. Having a fully operational ground control station that provides reliability, easy setup, safety, adaptability, easy decision making, among others, is a key point for the success of any unmanned aerial system mission. Therefore, the design and assembly of a ground control station for long range and long endurance unmanned aerial vehicles is presented. The mission requirements are derived from civilian surveillance applications, such as forest, coast or border patrol. The main steps of the design and assembly are covered as well as the description of each system and component and how they operate together to comprise a ground station. The feasibility of a low cost mobile ground control station for missions up to 8h and 100km range is demonstrated.

**Keywords:** Ground Control Station, Unmanned Aerial Vehicle, Unmanned Aerial System, Long Endurance, Long Range.



# Contents

Acknowledgments . . . . .	v
Resumo . . . . .	vii
Abstract . . . . .	ix
List of Tables . . . . .	xv
List of Figures . . . . .	xvii
Nomenclature . . . . .	xix
Glossary . . . . .	xix
<b>1 Introduction</b>	<b>1</b>
1.1 Motivation . . . . .	1
1.2 Context . . . . .	3
1.3 Objectives and Deliverables . . . . .	4
1.4 Thesis Outline . . . . .	5
<b>2 Unmanned Aerial Systems</b>	<b>7</b>
2.1 Unmanned Aerial Vehicles . . . . .	8
2.2 Ground Control Stations . . . . .	11
2.2.1 Basic Requirements . . . . .	12
2.2.2 Basic Systems . . . . .	15
<b>3 Problem Definition</b>	<b>19</b>
3.1 Mission Requirements . . . . .	19
3.1.1 Missions . . . . .	19
3.1.2 Aircraft . . . . .	20
3.1.3 Operational Range . . . . .	21
3.1.4 Object Detection and Tracking . . . . .	23
3.2 Ground Control Station Constraints . . . . .	24
3.2.1 Trailer . . . . .	24
3.2.2 Power/Energy . . . . .	24
3.3 Human Systems Integration . . . . .	25
3.3.1 Human Factors Engineering . . . . .	26
3.3.2 Habitability and Ergonomics . . . . .	26

3.3.3	Others . . . . .	27
3.4	Cost . . . . .	28
<b>4</b>	<b>System and Components</b>	<b>29</b>
4.1	Main Systems . . . . .	29
4.1.1	Flight Control . . . . .	29
4.1.2	Communication . . . . .	31
4.1.3	Electrical . . . . .	36
4.2	System Architecture . . . . .	41
4.3	List of Components . . . . .	42
4.3.1	Power . . . . .	42
4.3.2	Video, Communications and Antennas . . . . .	44
4.3.3	Computer and Human Interface . . . . .	46
4.3.4	RC Controller and Video Recording . . . . .	46
4.4	Electrical Schematic . . . . .	47
4.4.1	Power Supply . . . . .	48
4.4.2	Computer System . . . . .	49
4.4.3	Video System . . . . .	49
4.4.4	Radio System . . . . .	50
4.4.5	Other . . . . .	50
4.5	Power Budget . . . . .	51
<b>5</b>	<b>Layout</b>	<b>53</b>
5.1	Overview . . . . .	53
5.2	Operator Interface . . . . .	53
5.3	Structure . . . . .	55
5.4	Cable Management . . . . .	56
5.5	List of Materials . . . . .	57
5.5.1	Wiring . . . . .	57
5.5.2	Power Supply Components . . . . .	57
5.5.3	Computer System . . . . .	58
5.5.4	Video System . . . . .	58
5.5.5	Radio System . . . . .	58
5.5.6	Other . . . . .	59
5.5.7	Structural Material . . . . .	59
5.6	Implementation Plan . . . . .	59
<b>6</b>	<b>Implementation</b>	<b>61</b>
6.1	Overview . . . . .	61
6.2	Structure . . . . .	61

6.3	Electrical . . . . .	63
6.3.1	Electrical Board and central Panels . . . . .	64
6.4	Final Assembly and Basic Testing . . . . .	64
<b>7</b>	<b>Conclusions</b>	<b>67</b>
7.1	Achievements . . . . .	67
7.2	Future Work . . . . .	67
	<b>Bibliography</b>	<b>69</b>
<b>A</b>	<b>System Schematics</b>	<b>75</b>
<b>B</b>	<b>Technical Datasheets</b>	<b>77</b>
B.1	Structure Thecnical Drawings . . . . .	77



# List of Tables

2.1	UAS Categories . . . . .	9
3.1	LEEUAV Specifications . . . . .	20
3.2	Trailer Dimensions . . . . .	24
4.1	RF link distance for 433MHz . . . . .	35
4.2	RF link distance for 868MHz . . . . .	35
4.3	ESSENTIALS@230VAC systems power consumption . . . . .	51
4.4	ESSENTIALS@12VDC systems power consumption . . . . .	52
5.1	Required quantity of 230VAC wire . . . . .	57
5.2	Power supply component list . . . . .	58
5.3	Computer system component list . . . . .	58
5.4	Video system component list . . . . .	58
5.5	Radio system component list . . . . .	59
5.6	Other system component list . . . . .	59
5.7	Required MDF parts . . . . .	59





# List of Figures

1.1	Wildfire Monitoring . . . . .	1
1.2	Camera a board a UAV . . . . .	2
1.3	Sea Patrol . . . . .	2
1.4	Good transportation . . . . .	2
1.5	LEEUAV Prototype . . . . .	3
1.6	LEEUAV GCS Antennas . . . . .	4
1.7	LEEUAV GCS . . . . .	4
1.8	UAS components . . . . .	4
2.1	Example of an UAS . . . . .	7
2.2	UAS components . . . . .	8
2.3	UAV examples in [18] . . . . .	9
2.4	Different class UAVs . . . . .	10
2.5	Application of UAVs in various fields . . . . .	11
2.6	Predicted Value of UAV Solutions in Key Industries (Billion) by 2027 . . . . .	11
2.7	Examples of GCSs . . . . .	12
2.8	Basic Key GCS Requirements . . . . .	13
2.9	UAS Architecture . . . . .	16
2.10	GCS Systems . . . . .	18
3.1	LEEUAV Typical profile . . . . .	19
3.2	3D Drawings of LEEUAV . . . . .	20
3.3	Line of Sight . . . . .	21
3.4	LOS Calculation . . . . .	22
3.5	GCS at DRL . . . . .	23
3.6	Trailer – Real and CAD model . . . . .	25
3.7	Human Performance . . . . .	25
3.8	Cockpit examples . . . . .	27
4.1	GCS Main Systems . . . . .	29
4.2	Flight Control Sub Systems . . . . .	30
4.3	Mission Planner Interface . . . . .	30

4.4	Communication Subsystems . . . . .	31
4.5	Mavlink message . . . . .	32
4.6	PPM Signal . . . . .	32
4.7	Yagi and Parabolic working principle . . . . .	33
4.8	Different types of polarization . . . . .	34
4.9	Scheme of the video system . . . . .	36
4.10	Specific energy density . . . . .	37
4.11	Different UPS types . . . . .	38
4.12	Power System Architecture . . . . .	40
4.13	Automatic Transfer Switch Modes . . . . .	40
4.14	System Architecture . . . . .	41
4.15	Power system components . . . . .	43
4.16	Telemetry radio 3DR Robotics . . . . .	44
4.17	Scherrer TX 700 PRO UHF . . . . .	45
4.18	Video system components . . . . .	45
4.19	GCS's Antennas . . . . .	46
4.20	Display Screens . . . . .	46
4.21	Transmitter Duplex DC-14 EX MM RC Controller . . . . .	47
4.22	Electrical schematic draft . . . . .	47
4.23	Central panel concept . . . . .	48
4.24	Electrical Schematic 1 . . . . .	49
4.25	Electrical Schematic 2 . . . . .	49
4.26	Electrical Schematic 3 . . . . .	50
4.27	Electrical Schematic 4 . . . . .	50
4.28	Electrical Schematic 5 . . . . .	51
5.1	Ground Control Station . . . . .	53
5.2	Operator Interface . . . . .	54
5.3	Central Indicator and Control Panel . . . . .	55
5.4	Assembled MDF structure concept model . . . . .	56
5.5	GCS's cable management draft . . . . .	56
6.1	IST laboratory CNC machine manufacturing . . . . .	62
6.2	FabLab Lisboa CNC machine manufacturing . . . . .	62
6.3	MDF structure and electric board panel fixation . . . . .	63
6.4	Wiring of some of the 230VAC and 12VDC grids . . . . .	63
6.5	Electrical Board and central Panels . . . . .	64
6.6	Final layout . . . . .	65
6.7	Final layout . . . . .	66

# Glossary

<b>CAD</b>	Computed Aided Design is the use of computer based software to aid in design processes.
<b>GCS</b>	Ground Control Station is the set of computers, displays, radios receivers and antennas that enable the exchange of commands and telemetry data between an UAV and the operator.
<b>LEEUAV</b>	Long Endurance Electric Unmanned Aerial Vehicle is a prototype that can carry on missions up to 8 hours endurance only by electric means.
<b>MAVLINK</b>	Micro Air Vehicle Link is a communication protocol for unmanned systems, where each packet consists in a stream ranging between 12 and 280 bytes which contains the data to be sent.
<b>OS</b>	Operating System is the program that, after being initially loaded into the computer by a boot program, manages all of the other application programs in a computer.
<b>PPM</b>	Pulse Position Modulation is a technique that allows variation in the position of the pulses according to the amplitude of the sampled modulating signal.
<b>UAS</b>	Unmanned Aerial System is comprised of the GCS and one or more UAVs.
<b>UAV</b>	Unmanned Air Vehicle is an aircraft piloted by remote control or on board computers.



# Chapter 1

## Introduction

### 1.1 Motivation

Unmanned Aerial Systems (UAS) technologies are in constant evolution. Since they were introduced in World War II [1], mankind pushed their limits to obtain better and more resourceful features that have been increasing the duration and quality of Unmanned Aerial Vehicles (UAV) missions, either in military or civilian applications.

The increasing number of applications for UASs is raising the investment and research on this field, allowing the development of new technologies and implementation techniques. Independently of its objective, whether it is Wildfire Monitoring [2], Good Transportation [3], Sea Patrol [4], the planning of the UAV mission happens before take off and has to take into account several factors, such as its path, duration and the need of a permanent pilot on the ground. Regarding the long range and beyond

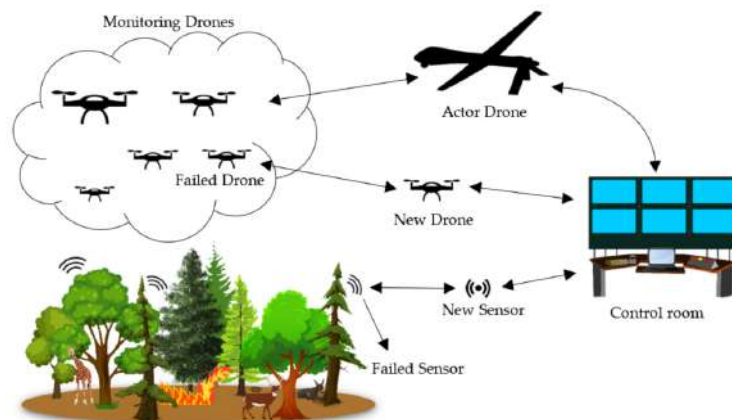

Figure 1.1: IOT and UAS based Forest Fire Detection and Counteraction System [2]

sight missions, it is crucial that the operator can see images of the surroundings of the UAV in real time. Several developments have been made in this field, as can be found in [5] where an example of a specific solution to this problem is presented. Different strategies can be implemented to achieve vision, namely the use of a fixed camera or the use of gimbals, that give the operator freedom to look around freely. In Fig.1.1 it is possible to see the concept of an UAS, that together with IOT applications,

can leverage its performance even further by relaying in additional data from sensors on the ground.



Figure 1.2: OGASSA - Video imaging using an electrooptic gimbal

While everything is processed in the air by the onboard computer, on the ground the operator should give inputs to specify which object the UAV should follow and detect on the Ground Control Station (GCS) interface. That should be done during the mission planning or the mission itself. To do so the UAV and the GCS must be linked. Taking advantage of the advancements in telecommunications over the last years, the most common method is to establish a Wi-Fi network in the 2.4 GHz (802.11b/g/n) band [7] as can be seen in UAVision OGASSA UAV model presented in 1.4.



Figure 1.4: Drone postal and goods delivery

There are missions whose purpose include the identification and following/tracking of targets. This can be achieved by implementing machine vision to automatically detect objects in the camera's image stream combined with the UAV's navigation data. With that, the onboard computer is able to georeference each object detection to measure the location of the detected objects in a local North-East coordinate frame and then give the necessary instructions to the UAV flight computer to follow the target [6].



Figure 1.3: OGASSA OGS42 - last generation UAV by UAVision for long range missions. [4]

To ensure reliability and fidelity both the antennas on the GCS and on-board the UAV have to be thought out in detail. At first sight the reader would be thinking about directional antennas. From design principle, directional antennas are known to focus their signal energy in a particular direction viewed from their radiation pattern, which is concentrated in a particular azimuth direction. Unfortunately, a directional antenna is limited by angle, thus, it must always be directed to the target. The other limitation of a UAV mechanical beam steering system is that the system is expensive to

maintain and has low reliability. An elegant solution is presented in [8] by using MIMO beam forming.

Society is evolving into a new Era. With the advance of technology, possibilities are many which take us to the reason why this thesis work came to life.

## 1.2 Context

This thesis follows several others completed in the past. Starting with the work done by Rodrigues in [9], where the use of solar power in a long endurance electric UAV is studied.

The LEEUAV is a prototype of 4.5 meters wingspan and ultralight structure, with solar panels incorporated, that enables the aircraft to fly on long missions up to 8 hours endurance. The LEEUAV's preliminary and conceptual design was carried out by UBI, whose main objectives and tests were successfully achieved by Cândido [10].

After that, Ferreira [11], from IST, studied several propulsion systems ending with Sousa proposal to validate the LEEUAV's solar propulsion system [11]. Years after, Duarte [12] designed, analysed and built the carbon fibre fuselage, tail boom and control surfaces of LEEUAV.

The LEEUAV was ready to fly, but there was still work to do. The influence of the solar panels thickness in the low speed airfoil of the LEEUAV was studied by Freitas [13] and Moutinho [14] implemented a way of streaming solar energy system data in real-time to the ground station in Fig.1.7.

In the end, an aircraft capable of endure 8h flying was built, with 4.5 m wingspan and 2.3 m length, the UAV needs about 8.1m to take off. Also, its MTOM is 4.9 kg and maximum speed 21.1 m/s. An image of the UAV is displayed in Fig.1.5.

In order to communicate with the GCS, three independent communication protocols where implemented: for flight control inputs at long distances, for feed-back information from on-board sensors (telemetry) and for video streaming (FPV).

On the ground, all data has to be caught by 3 different antennas that can be seen in Fig.1.6.



Figure 1.5: LEEUAV without solar painels [9]

The system in Fig. 1.6 that together with the ground control station in Fig. 1.7 is capable to operate the aircraft up to distances up to 100 km. The present work aims to design and upgrade to this existent GCS.

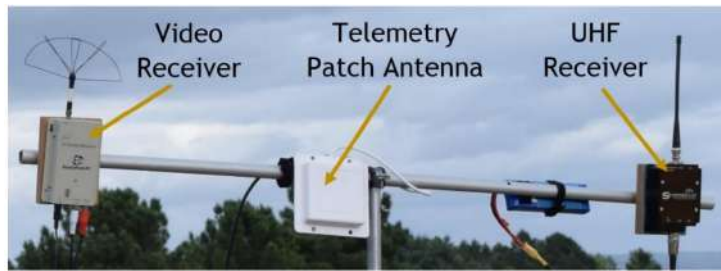

Figure 1.6: GCS antennas of LEEUAV [9]



Figure 1.7: LEEUAV Ground Control Station [9]

### 1.3 Objectives and Deliverables

With all the work previously done by colleagues, the focus of this thesis is to design and build a ground control station that can be deployed in the field as part of an unmanned aerial system (UAS) as schematically illustrated in Fig.1.8

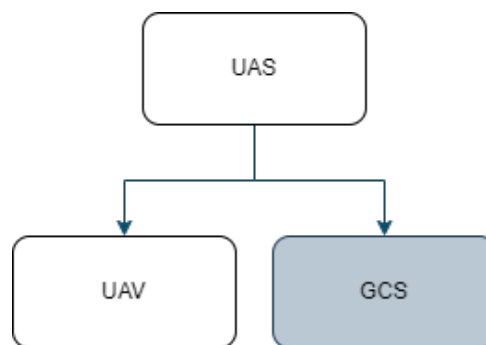

Figure 1.8: Focus of work

Starting with an existing trailer, a control room has to be envisioned, using virtual reality and CAD tools, to satisfy both functionality, reliability, redundancy and ergonomic constraints. Once these constraints are satisfied, a detailed description of the power supply, video, telemetry and control hardware requirements should be made taking into account the LEEUAV project, subsequently leading to the



selection of every hardware component to be installed in the GCS. To do so, the objective includes:

- Learn about the concepts inherent to UAS. Understand the basic requirements of a UAS system with focus in GCS as its main systems and how they operate;
- Define detailed GCS requirements and constraints based on the LEEUAV project;
- Selection of all the components required in the GCS. A list of components along with both system architecture and electrical schematic shall be done;
- Design of the GCS in Computer Aided Design (CAD), definition of implementation plan and list of materials;
- Implementation and basic operating systems testing. Experimental validation of the system. An User's Guide/Instructions manual will be attached to this worked in order to facilitate the use and improvement of this GCS.

The following deliverable shall be included in the delivery of the present work:

- GCS fully built and operational
- GCS User Guide including Preflight, Flight modes and Checklists.

## 1.4 Thesis Outline

After a brief introduction of the main subject of this work this document was written with a logical order going from the general to the specific problem that is the design and assembly of a GCS.

This document comprises of six main sections:

- **Unmanned Aerial Systems:** UAS basic concepts are introduced as well as its subsystems namely UAVs and GCS. More specifically the GCS's basic requirements and systems are explained.
- **Problem Definition:** This section includes the LEEUAV mission requirements as well as the GCS requirements and constraints.
- **System and Components:** Includes the GCS main subsystems namely flight control, communications, data recording and electrical.
- **Layout :** the concept of implementation of the GCS is shown and explained.
- **Implementation :** manufacturing and assembly process of the several GCS's parts and systems.



## Chapter 2

# Unmanned Aerial Systems

Unmanned aircraft system (UAS) means an unmanned aircraft and the equipment to control it remotely.

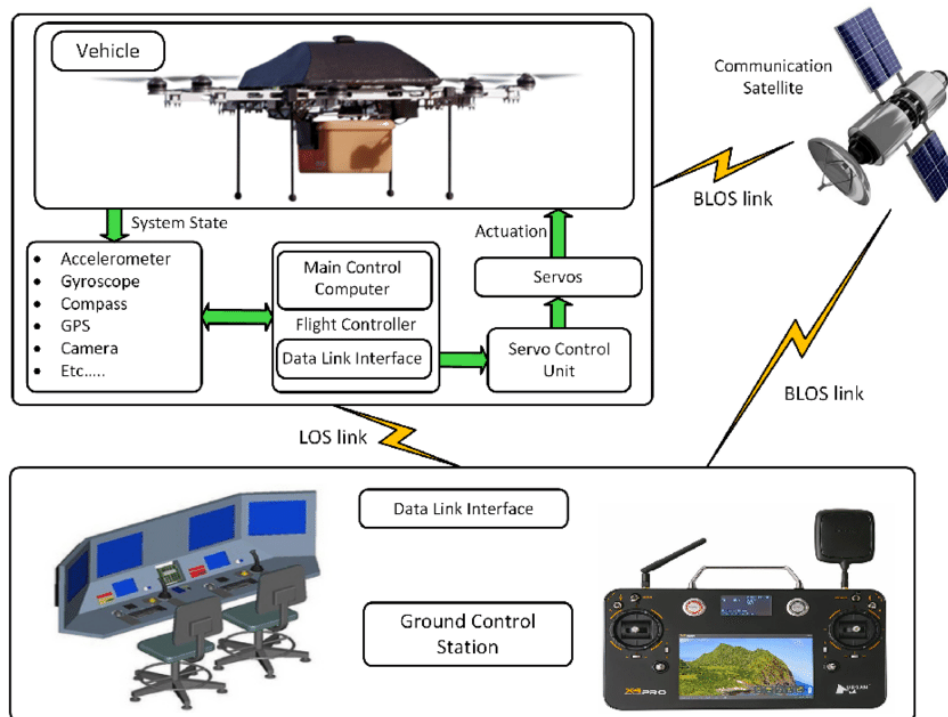

Figure 2.1: Unmanned Aerial System [15]

An UAS is composed by two major components:

- An Unmanned Aerial Vehicle (UAV) ;
- An autonomous or human-operated control system which is usually on the ground or a ship but may be on another airborne platform (GCS);

The vehicle in order to perform unmanned maneuvers shall incorporate many sensors, as described in Fig.2.1, to acquire all the data to read and estimate the current state of the aircraft. When a control

command is given from the GCS, usually through a radio link between the two, the flight controller compares the command with the current state and generates a signal that is forwarded to the control unit of the actuators. This link can be done directly with just two antennas or beyond line of sight with the help of other systems, a satellite for example. On the ground, the command is given by the human interface in the GCS that can be a room full of many features or just a mobile remote control that supports basic operations.

With the increased use of these systems and their associated operations risk, being the principal cause of unexpected events, the EASA regulates this field by defining 3 categories for UAS operations in EU territory: 'open', 'specific' or 'certified', defined respectively in Articles 4, 5 and 6 [16], subject to the conditions:

- The 'open' category addresses the lower-risk civil drone operations, where safety is ensured provided the civil drone operator complies with the relevant requirements for its intended operation. Operational risks in the 'open' category are considered low and, therefore, no operational authorization is required before starting a flight;
- The 'specific' category covers riskier civil drone operations, where safety is ensured by the drone operator by obtaining an operational authorization from the national competent authority before starting the operation. To obtain the operational authorization, the drone operator is required to conduct a risk assessment, which will determine the requirements necessary for the safe operation of the civil drone(s);
- In the 'certified' category, the safety risk is considerably higher; therefore, the certification of the drone operator and its drone, as well as the licensing of the remote pilot(s), is always required to ensure safety.

## 2.1 Unmanned Aerial Vehicles

Eisenbeiss [17] defined Unmanned Aerial Vehicle (UAV) which covers all vehicles, which are flying in the air with no person onboard with capability on the ground for controlling the aircraft. There are several ways this can be accomplished as shown in Fig.2.3. This section will discuss some military applications for UAV's and learn about NATO's classification system. Also, UAV civil applications and their market growth in the years to come will be mentioned, Fig.2.2

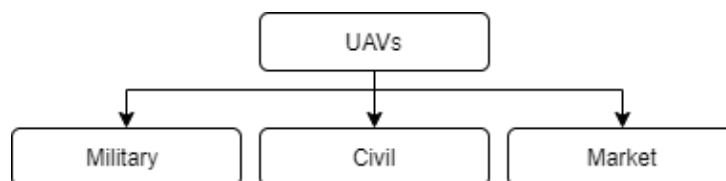

Figure 2.2: Topics explained in this section



Figure 2.3: Representative examples of small tactical UAVs and representative examples of miniature UAVs in [18]

Globally, there are many UAV classifications, but since we live under the regulations of European Commission only the EU classification is elicited here. These regulations UAV's include three subcategories A1, A2 and A3 as described in Tab.2.1 :

UAS		Operation		Drone operator/pilot		
Max weight	Subcategory	Operational restrictions	Drone operator registration	Remote pilot competence	Remote pilot minimum age	
< 250 g	A1 (can also fly in subcategory A3)	<ul style="list-style-type: none"> <li>No flight expected over uninvolved people (if it happens, overflight should be minimised)</li> <li>No flight over assemblies of people</li> </ul>	No, unless camera / sensor on board and the drone is not a toy	<ul style="list-style-type: none"> <li>No training required</li> </ul>	No minimum age	
< 500 g			Yes			<ul style="list-style-type: none"> <li>Read carefully the user manual</li> <li>Complete the training and pass the exam defined by your national competent authority or have a 'Proof of completion for online training' for A1/A3 'open' subcategory</li> </ul>
< 2 kg	A2 (can also fly in subcategory A3)	<ul style="list-style-type: none"> <li>No flying over uninvolved people</li> <li>Keep a horizontal distance of 50 m from uninvolved people</li> </ul>	Yes	<ul style="list-style-type: none"> <li>Read carefully the user manual</li> <li>Complete the training and pass the exam defined by your national competent authority or have a 'Remote pilot certificate of competency' for A2 'open' subcategory</li> </ul>	16*	
< 25 kg	A3	<ul style="list-style-type: none"> <li>Do not fly near or over people</li> <li>Fly at least 150 m away from residential, commercial or industrial areas</li> </ul>	Yes	<ul style="list-style-type: none"> <li>Read carefully the user manual</li> <li>Complete the training and pass the exam defined by your national competent authority or have a 'Proof of completion for online training' for A1/A3 'open' subcategory</li> </ul>	16*	

Table 2.1: EU regulations "open" category sub categories [16]

The LEEUAV fits in the A3 subcategory. That implies that no flight shall be made under 150m from a residential, commercial or industrial area. The pilot will need to be registered and have an authorization issued by ANAC, the regulatory entity in Portugal, since although the mass of the aircraft is below the 25Kg, it has a camera on board [19].

## Military applications

The UAVs were born during the WWI [20]. The need to save lives in battle took the best minds into achieving these beautiful aircraft that NATO classifies as :

- CLASS I (< 150 kg: MICRO, MINI OR SMALL DRONES -provide ISTAR (Intelligence, Surveillance, Target Acquisition and Reconnaissance), Fig.2.4(a);
- CLASS II (150-600 kg ): TACTICAL - have a vital role in filling the gap between the range of functions of the short-range micro-UAVs and the strategic UAV, Fig.2.4(b);
- CLASS III (>600 kg): STRATEGIC - include those used to determine the position of the enemy or the movement of certain populations that are not involved into a conflict, Fig.2.4(c).

Having many applications in the military field, such as target and decoy, reconnaissance and combat, these airmachines carry on them the state of the art infrastructure.



(a) Class I UAV – Launched by a person



(b) Class II UAV



(c) Class III UAV – Northrop Grumman RQ-4 Global Hawk

Figure 2.4: Different class UAVs

## Civil applications

As highlighted in Fig.2.5, the main civilian applications are rescue operations, saving lives, agriculture and farming, building structures, pipeline inspections, delivering goods and medical supplies, video capturing and filming and surveying. There are many more uses beyond these such as inventory management, monitoring activities and providing relayed telecommunication services.

## Market growth

There is an endless number of missions that UAVs can do nowadays but what can the hold the future? A study conducted by Ahmad Sawalmeh [22] expects that the UAV's market will be dominated by infrastructure inspections and by agriculture, reaching 45B USD and 32B USD, respectively, by 2027. Transportation applications are right in third accordingly with [22] but another study by Business Wire expects that the same application market reach US 33.6B USD by the same period, Fig.2.6.

These studies make the total UAV market around 120B USD and just to have a comparison with the rest of the Aerospace market, the study made by The Business Research Company [23] says that the

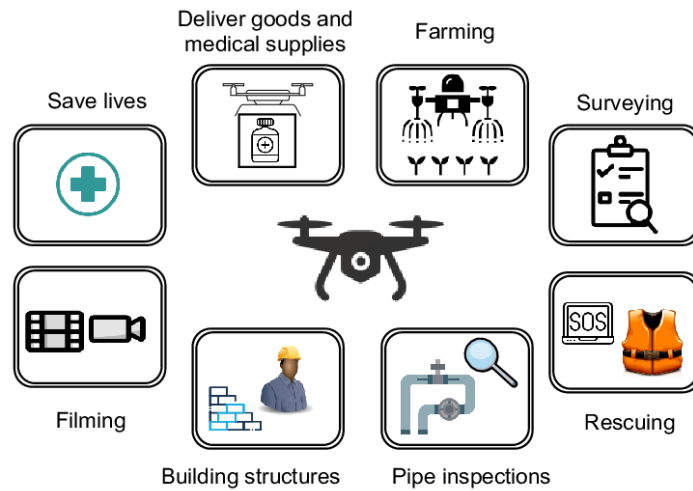

Figure 2.5: Application of UAVs in various fields [21]

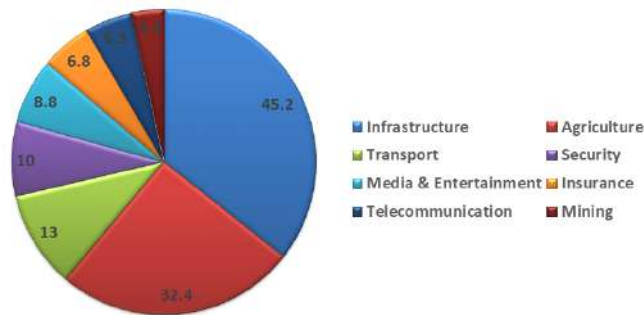

Figure 2.6: Predicted Value of UAV Solutions in Key Industries (Billion) [22] by 2027

global aerospace market will be valued around 500BUSD between 2025 and 2030. This implies that the UAV market share will be around 22 %.

## 2.2 Ground Control Stations

There is a wide range of different ground control stations and this section intends to scrutinize this topic.

The Ground Control Station is the command and central hub for remotely piloted aircraft. The wide range of different types and designs of GCS is a consequence of the requirements for specific applications. GCS can be stationary, shipboard or mobile, from small to big they vary in shape and size.

In Fig.2.7 (a), it is possible to see the Dual Screen UAV Ground Station 12PCX HOTAS HD Portable GCS [26]. With two Ultra HD 1900×1200 LCD displays, the operator is able to assign channels and functions to the preferred buttons, dials and joysticks even in the sunlight. In addition, it is very easy to change any component in case of malfunctioning by quickly swapping any video receivers, antennas, RF modules and the computer, making this GCS a highly modular system, easy to transport and easy



Figure 2.7: Examples of GCSs

to take to the field.

Sometimes the mission can require the GCS to travel kilometers to a remote place where power can be a problem. A solution to that specific problem in Fig. 2.7 (b) is presented. Fully equipped with everything since antennas, power generators, as well as the computers to operate the UAV's, the German Aerospace Center uses this van to test their in-development UAV's [24].

But in case long endurance missions and military operations where failure must not be an option, the GCS shall be reliable in terms of communication range, power and fidelity. In that case a good example can be the GA-ASI Certifiable GCS, Fig.2.7 (c). Since its first flight in 2018 [27] it has been used to fly the MQ-9B SkyGuardian which was what it was designed for. GA-ASI Certifiable GCS features an enormous amount of capabilities that common GCS's do not have. Equipped with the Pro Line Fusion integrated avionics system from Collins Aerospace this GCS is able to create an intuitive visual environment by adding distinct mile markers, runway highlights, lead-ins and airport domes to help pilots easily identify destination airports. This GCS has an intuitive interface that displays the terrain, obstacles and even detect bad weather as they appear ahead of the aircraft making the flight decisions and operations much easier for the remote pilot. In operation, two elements can be considered, a Launch and Recovery Element (LRE) and a Mission Control Element (MCE). While the LRE is responsible for flying the UAV as it travels to and from an area of interest, the MCE assumes control when the UAV reaches the area of interest, and includes a pilot and a sensor operator [28]. This GCS features two operators as well as two redundant Pilot/Sensor Operator (PSO) stations. It supports manual pilot-in-the-Loop to fully automated operations, separation of flight and mission critical functions. Each PSO station incorporates F-35/F-16 inspired hands on throttle and stick (HOTAS) and five high-definition (1080p) touch-screen displays in which the user can see navigation charts, imagery of the payload and tactical situation. In addition, the operator is also able to do the flight planning, mission planning and management, data dissemination and Analysis and all sort of communications.

## 2.2.1 Basic Requirements

While initiating the design of a ground control station, it is important to define the "need to have" and "nice to have" requirements. These are chosen taking into account the operations and missions



for which the ground control station will be used and the UAV capabilities controlled by the GCS. In this subsection a few aspects ([29] and [30]) that shall be taken into account will be enumerated as displayed in Fig.2.8.

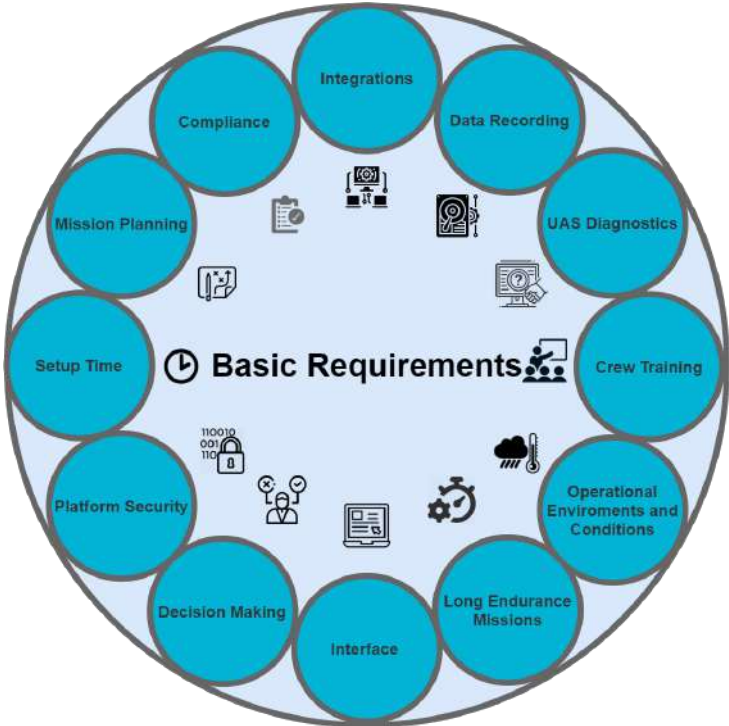

Figure 2.8: Key basic requirements ([29] and [30])

**Decision Making**

While having no connection between the GCS and the UAV, the GCS shall show in the Head-Up Display (HUD) a warning signal showing that connection is lost and shall execute a fail safe command.

**Mission Planning**

Before flight, the operator shall analyze the local weather forecast, the surrounding orography and obstacles, and shall define a flight plan.

**Data-Recording**

During any flight the telemetry, video and commands shall be saved and stored for post-flight review.

**Unmanned Aircraft Systems Diagnostics**

In case of malfunction, all systems shall be of easy access to facilitate their repair or substitution.

## **Crew Training**

The GCS operators shall be trained to follow some flight and emergency protocols. Easy to learn and intuitive features are recommended.

## **Operational environments and conditions**

The operational environment and conditions plays an important role in the design of any GCS. The environmental conditions affect the performance of the operation directly along with the reliability of the equipment. Natural and artificial phenomena such as weather or magnetic interference shall also be taken into account.

## **Extended Operations**

There are many requirements that long endurance operations require. For instance, the GCS shall be able to stay on for long periods of time, so its power system shall be able to endure that.

In addition, ergonomics is recommended to be taken into consideration. By designing a GCS platform that is ergonomic it will simultaneously not only improve the operator efficiency and satisfaction but also diminish the risk of human error.

## **Interface requirements**

User interface requirements have also several important topics that shall and should be taken into consideration.

For instance, the screen size can affect many aspects such as the software being used, portability and ergonomics. Although small size monitors are well suited for many of the software out there, the size should fit the operator needs. Beyond that, many missions may occur out in the sun and thus require sun-light readability.

Besides screens, buttons and switches may be included in the GCS. They impact the operator performance, ease of use and the safety of the operations, so their layout should be carefully considered. There are many types of buttons, switches, and joysticks and they should be chosen according to their purpose.

Because we are designing our own GCS there is full freedom on the customization of these components enabling more advanced use cases, such as the protection of specific functionalities and ensuring operator efficiency by using safety switches and by adding extra joysticks, respectively.

Although many GCS offer only joysticks and buttons, other offer full functional operating systems that provides the operator with advanced control of the system. This decreases the operator stress since software applications can be more user friendly and efficient to use.

## Setup-Time

In order to initiate an operation, all equipment needs to be set up and the times it take is refered as Setup-Time. To increase efficiency in operations, this is a key factor since it may impact the operator's safety and the operation's results. By diminishing the Setup-Time, both the operator stress and the risk of human error during the setup is reduced. This can be accomplishing by designing integrated solutions, such as a trailer with all the systems on board.

## Compliance

While designing the GCS and choosing its components, the level of serviceability shall be taken into consideration. In case of malfunctioning, the option of purchasing spare parts or even the ability to get the GCS repaired or serviced regularly can increase that. In addition, designing a GCS composed by components or parts that are discontinued can pose a risk.

## Platform Security

A crucial topic to be considered is the security. Security risks such as jamming, data leaks, availability of the GCS, take-over/hijacking of the equipment and risk of data-loss can be a key factor to compromise operations. Several counter measures can be implemented, such as updated platform software, communication encryption and by enforcing enterprise cyber security policies.

## Integrations

Integrators or users of ground control stations can be met with compliance requirements when delivering products or services to certain markets. Therefore, it can be relevant to consider the GCS's compliance in terms of NDAA, ITAR, or standards such as MIL-810G. More research should be done about this topics.

### 2.2.2 Basic Systems

In this section, the basic systems of a GCS will be discussed. In terms of connectivity between the UAV and the GCS three interfaces shall be implemented to fulfill three major tasks, as studied in [31] and shown in Fig. 2.9

The UAV shall be able to send data and receive commands to and from the GCS in order to perform several actions. Changing direction or even following a target object. Three types of data are required to be transmitted between the UAV and the GCS.

- **Video Stream** - imagery from cameras aboard the UAV
- **Manual Control Commands** - commands from the Mission Planner or either from the manual pilot;

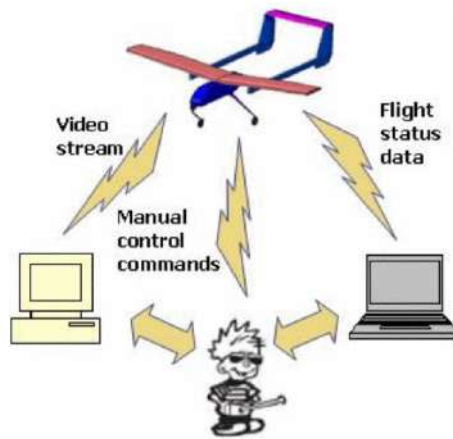

Figure 2.9: UAS Architecture [31]

- **Flight Status** - telemetry to be transmitted via MAVLINK (Micro aerial vehicle link) between the GCS and the UAV.

While these three data types are transmitted to the GCS, the operator has the tasks of tracking the UAV waypoints, navigating the aircraft around by sending direct commands or coordinates depending on the flight mode chosen at the moment.

Many autopilot software platforms have already been developed and are available: ArduPilot, Parrot UAV developed at Ecole Nationale de l'Aviation Civile (ENAC), Hangar autopilot, PX4 Flight Stack, MultiWii from Nintendo are just a few.

The most prominent is ardupilot, an interoperable Open Source software for this kind of application being effectively maintained by about 400 contributors and having the possibility of monitoring several autonomous systems, fixed and rotating wing, (heli, tri, quad, hexa, and octo) aircraft, underwater vehicles and boats, and ground vehicles, makes it the most versatile. It is also easy to implement due to its well documented guides and tutorials.

In order to transmit commands in the form of messages, Micro Aerial Vehicle Link (MAVLink protocol) [32] is used in the ArduPilot software. MAVLink is a bidirectional system that connects both the ground station and the unmanned system by serializing the messages in a binary way. Typically, its messages are of small sizes and can reliably be transmitted over different wireless mediums, including WiFi or even serial telemetry devices with low data rates. Ensuring reliability and message integrity by a double checksum verification, the MAVLink protocol is the most popular among its peers for the communication in unmanned systems.

In the most recent works done by Moutinho [14, 17] they explain in good detail how the GCS systems interconnect between each other, as displayed in Fig.2.10, setting our base for conceiving the trailer GCS. Composed by four main subsystems, a basic GCS system architecture is described next, stating what main function of each subsystem is.

## Flight Control

- **Computer** - runs the Mission Planner software, which in turn handles all the received telemetry data software;
- **Radio Control System** - set of electronics or any radio controlled model which allows to be operated via wireless remote control. Composed by a transmitter and a receiver, this is what allows sending commands to the UAV on the hardware layer;
- **Mission Planner Software** - there are many softwares to handle the telemetry received, flight modes and commands sent to the UAV. Mission Planner[33] was the one chosen in the LEEUAV project and is the most popular among the community;
- **Screen Displays** - their main function are basically displaying the video received from the cameras aboard the UAV;

## Land-Air Communication System

- **Telemetry Receiver** - device or set of electronics capable of receiving the data from the UAV using a specific frequency;
- **Antennas** - for the three communication links, different antennas are required. They can vary in size, frequency and power;
- **Video Receiver** - to demodulate the video stream received from the on board cameras in the form of electromagnetic waves, a video receiver is used;
- **Radio Transceiver/Receiver** - RF module responsible for sending and receiving data. It can be the same as the RC System;

## Electrical System

- **Power Sources** - for everything to work, a power or multiple power sources shall be implemented;
- **Power Distribution** - to accommodate the power to the level specified for each system, a distribution and managing power system needs to be included in the GCS;

- **Cabling** - considering ergonomics, serviceability and volume limitation, cable management is another important factor to be thought;
- **Video Controller** - when two channels are used for transmitting video, a controller is needed to add data from both channels in one and thus outputting it to common interface such as PAL or NTSC.

## Recording System

- **Video Recording** - during a mission, it can be important to record the video from the flight for further analyses and a system is needed for that;
- **Flight Data Recording** - on the same line of thought as above, a memory bank is needed for saving all the data received from the flight in what concerns telemetry.



Figure 2.10: GCS systems and subsystems

# Chapter 3

## Problem Definition

This chapter will be about the problem we want to solve the Trailer GCS objectives and requirements taking into account the LEEUAV project and its missions needs.

Starting with the mission requirements of the LEEUAV, we will explain the LEEUAV mission as well as several of its aspects, ending with several GCS constraints that should be met in order to implement a GCS using the existent trailer.

### 3.1 Mission Requirements

The LEEUAV mission was decided on a consortium meeting of Aeronautics and Space of Associated Laboratory for Energy, Transports and Aeronautics (LAETA)[9].

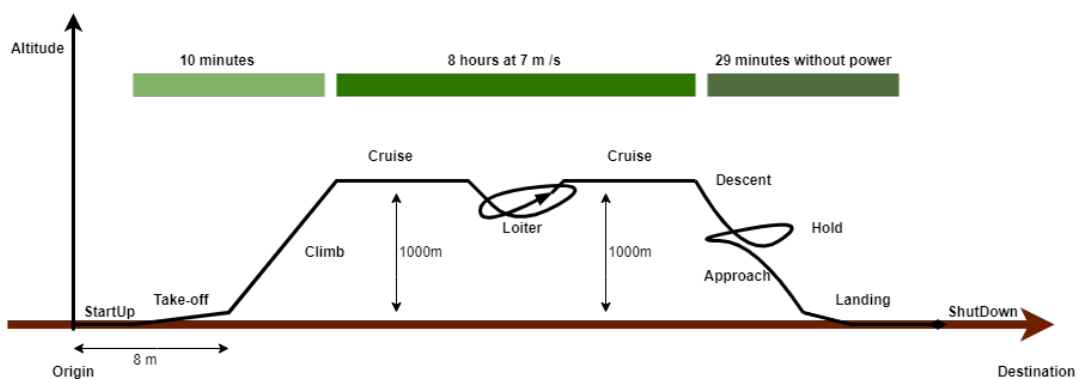

Figure 3.1: LEEUAV typical profile

#### 3.1.1 Missions

The goal was to design a vehicle capable of flying for at least 8 hours at the equinox with low power requirements and carrying a payload of up to 1kg. The mission profile also requires a short take-off and landing distance, high flight altitude (at least 1000 meters) and a descent without power.

Table 3.1: LEEUAV specifications [9]

Dimensions	Wingspan [m]	4.525	Weights	Empty Weight [N]	47.118
	Lenght [m]	2.557		MTOW [N]	54.129
	Height [m]	0.334		Payload [N]	9.81
	Mean Chord [m]	0.330		Structure Weight [N]	22.09
	Wing Root Chord [m]	0.350	Performance	Take-off Distance [N]	8.100
	Wing Tip Chord [m]	0.250		Endurance [h]	8
	Wing Area [m <sup>2</sup> ]	1.490		Maximum Speed [m/s]	21.10
	Aspect Ratio [AR]	13.50		Stall Speed [m/s]	6.94

Many different missions can be accomplished by the fixed wing UAV. In this case the main applications will be to sea patrol and wild fires monitoring. A typical mission profile is displayed in Fig.3.1.

### 3.1.2 Aircraft

Although the main goal is to design the GCS to be used along with the LEEUAV prototype the ability to control several other remote vehicles can be interesting, taking into account the ArduPilot has the capability of controlling all kinds of multi-rotor, fixed wing aircraft, ground or nautical vehicles.

In the specific case of the LEEUAV, its specifications are show in Tab.3.1 and Fig. 3.2 both retrieved from [9].

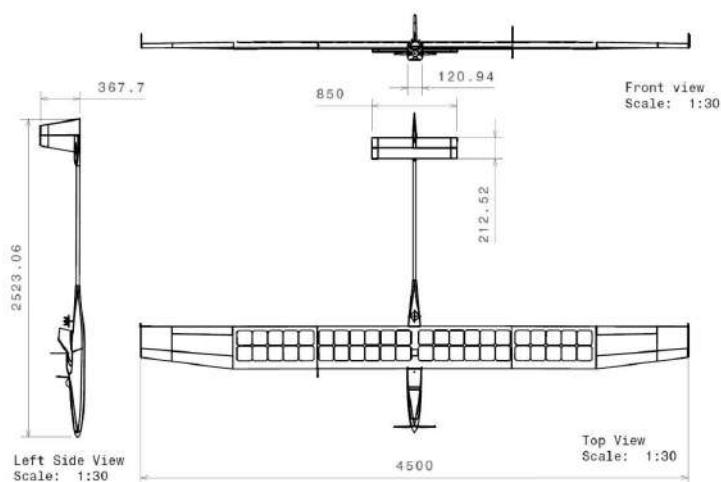

Figure 3.2: 3D Drawing views of LEEUAV [9]

Taking that into account, it would be desired to have room for transporting the LEEUAV in the trailer.



More about this topic is discussed ahead in Chapter 5 .

### 3.1.3 Operational Range

The operational range of the UAS represents a key factor to the success operations using the GCS and it depends on several aspects [34] such as the existence of line of sight, free space path loss (FSPL) and, of course, the sensitivity of radio modules used to exchange data between the GCS and the UAV as well as their antenna radiation and pattern gain.

#### Line of Sight

Even though the propagation of UHF band suffers diffraction over ten kilometers which then makes the wave to follow earth's curvature this phenomenon is substantial. In Fig.3.3, UHF band whose minimum communication distance is given by the limit in line of sight (LOS),

$$d = \sqrt{(R + h)^2 - R^2}, \quad (3.1)$$

where  $R$  is earth radius,  $h$  is altitude and  $d$  is distance.

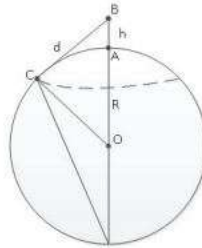

Figure 3.3: Line of Sight in [34]

This does not pose a problem for our application, as proven in Fig.3.4 that, taking into consideration the earth radius of 6371 km and using Eq. (3.1), displays the line of sight in function of the height of the aircraft.

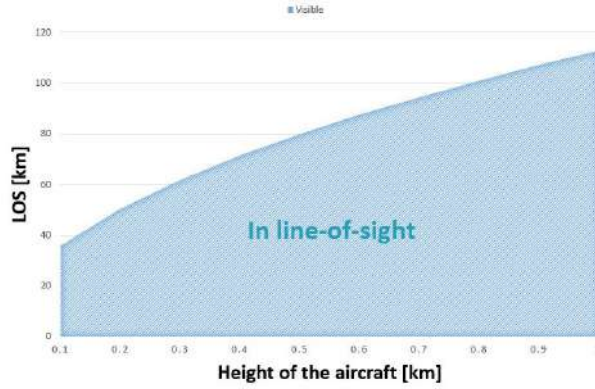

Figure 3.4: Line-of-sight as function of aircraft altitude

As shown in Fig. 3.4, when the aircraft is flying at an altitude of about 100 m, it can be seen up to 35 km. During climbing or descent, it is in LOS if it stays inside of the blue area of the graph.

### Path Loss and Link Budget Calculation

Besides the distance and altitude, the free space path loss (FSPL) is another important factor which depends essentially on the distance, the frequency of the carrier wave and the gains of receiver and transmitter Eq. 3.2:

$$FSPL = 32.45 + 20\log(d_{km}) + 20\log(F_{MHz}) - G_{tx} - G_{rx}, \quad (3.2)$$

where  $d_{km}$  is the distance in kilometers,  $F_{MHz}$  is the frequency in mega Hertz,  $G_{tx}$  and  $G_{rx}$  are the transmitter and receiver antenna gains, respectively. In another words, greater distances and higher frequencies contribute to the effect of path loss.

### Link Budget

Once the FSPL is known the link budget which can give an estimation of the success of communication can be given by Eq. 3.3:

$$P_{rx}[dBm] = P_{tx} + G_{tx} + G_{rx} - FSPL - F_m, \quad (3.3)$$

where  $P_{tx}$  and  $P_{rx}$  are the transmitted and received power, respectively and  $F_m$  stands for the fade margin. We can summarize that the success of communication is comprised of four aspects : the effective irradiated power of the transmitter, the antenna gains, the Free Space Path Loss(FSPL) and the receiver sensitivity. Succinctly, if  $P_{rx}$  is higher than the receiver sensitivity the communication is accomplished.

From Eq.3.2 and Eq.3.3, in free space without obstacles, the expected range for the RF link system

can be given by

$$\log_{10}(d_{km}) = \frac{P_{rx} - P_{tx} + 2G_{tx} + 2G_{rx} + 32.45 + 20\log_{10}(F_{MHz}) + F_m}{-20}. \quad (3.4)$$

where  $F_m$  stands for the added fade margin, typically of 20 dB. In Chapter 4, different transmitters and receivers used previously by other colleagues as well as a market survey will be compared.

To complement and according to Miller [5], the range of a transmission with antennas in LOS can also be predicted by the Friis transmission,

$$\frac{P_{rx}}{P_{tx}} = G_{tx}G_{rx} \left( \frac{\lambda}{4\pi R} \right)^2, \quad (3.5)$$

where  $G_{tx}$  and  $G_{rx}$  are the antenna gains,  $\lambda$  the wavelength and  $R$  the distance between the antennas.

### 3.1.4 Object Detection and Tracking

UAVs usually have a camera mounted on a gymbal which can be controlled by the operator on the GCS. Detecting and tracking an object at a distance is an important topic in what concerns UAS. Bearing that in mind, there are several open source developed projects in this field such as OpenCV [35] which is used for image processing. With this framework, it is possible to run TensorFlow algorithms based on machine learning methods that can automatically detect and identify what the camera is filming, for instance a person [36].

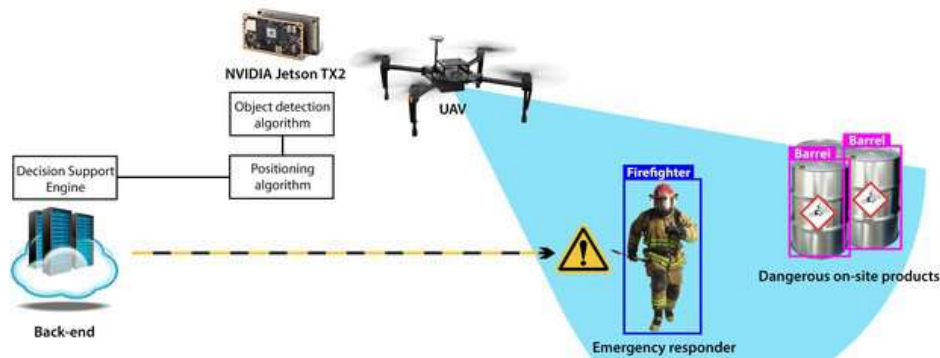

Figure 3.5: System architecture of a UAV-based decision support system for emergency response in [37]

In Fig.3.5 we can see an example of a method of a real time object detection studied in [37]. In this case, it is used a NVIDIA Jetson TX2 board for image processing that and several object detection algorithms are studied. The board can be either on the UAV or on the GCS.

## 3.2 Ground Control Station Constraints

Based on the trailer that was already available and all the basic requirements explained previously, the main constraints of the GCS to be built can be derived.

### 3.2.1 Trailer

To better envision and project what would be and how exactly would be arranged the several parts and components inside of the trailer I drawn with CAD software SolidWorks a model similar to the real trailer that can be shown in Fig.3.6(a) and Fig.3.6(b). In addition we can also see side by side pictures of the real and the CAD-Drawn version of the existent trailer.

Table 3.2: Trailer Dimensions

<b>Dimension</b>	<b>Value</b>	<b>Unit</b>
Width	1.87	m
Height	1.6	m
Length	3	m
Floor Area	5	$m^2$
Inside Volume	9	$m^3$
Weight	<750	kg

By analyzing the CAD model Tab.3.2 was filled and it is easy to find that the useful volume is about  $9 m^3$  and the useful interior area is about  $5 m^2$

### 3.2.2 Power/Energy

In order to power up all the systems required to make the GCS work properly during at least 8h period, a power and energy budget has to be calculated taking into account all of its components and its power consumption. On one side the GCS can be powered by any 230 VAC plug, but in a field mission that is not an option so an alternative source of power has to envisioned such as a fuel generator. In addition, in order to save fuel the systems shall be divided in two categories: critical and non-critical systems, representing the systems that are required to ensure a safely operation and the optional systems that are not required to the mission success, respectively. This will be further discussed in Sec.4.1.3.



(a) Inside view of the real trailer



(b) CAD-drawn trailer view from the inside



(c) Real trailer view from the outside



(d) CAD-drawn trailer view from the outside

Figure 3.6: Trailer – Real and CAD model

### 3.3 Human Systems Integration

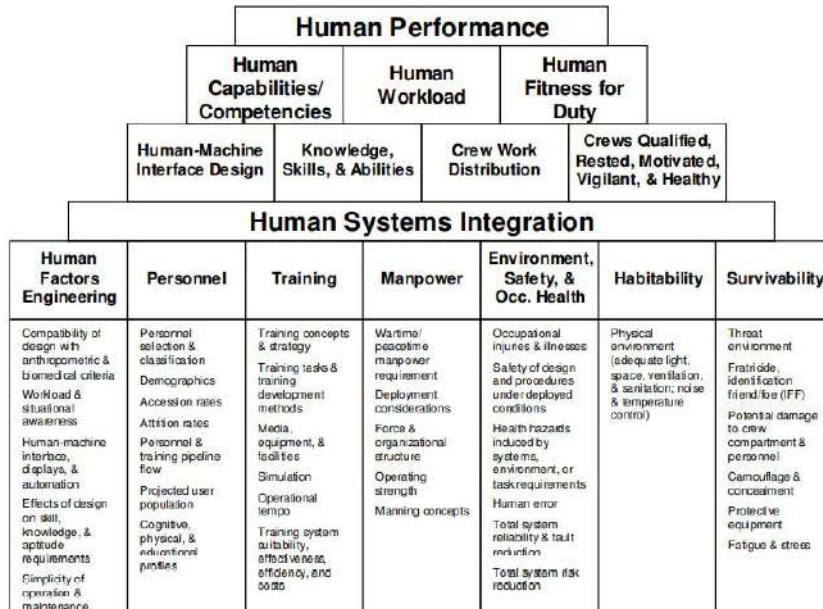

Figure 3.7: Human performance pyramid with human systems integration domains and areas of concern for each domain in [38]

Human interface represent a key factor in designing the GCS. As studied in [39], aspects like Human factors engineering, environment, safety, habitability, play a key role in the success of missions executed by the operators. In what concerns Human System Integration, Tvaryanas [39] states that people are the critical elements of the system and that adopting a human-centric perspective of systems increases productivity and safety while decreasing costs.

### **3.3.1 Human Factors Engineering**

GCS operators are very distinct from aircraft pilots because they lack peripheral visual, auditory, and haptic cueing making them relatively sensory deprived. Consequently together with factors such as knowledge and aptitude requirements, cognitive, physical and educational profiles, make the probability of human errors during missions high.

In large UAS, the implementation of a shift work for the crew members can provide the necessary rest and relief of stress which in turn increases effectiveness.

### **3.3.2 Habitability and Ergonomics**

Work shifts might not be enough to mitigate the loss of the operator performance during mission. For instance when the operator has to interact with the GCS, it is crucial that he do it in a optimal way. Ergonomics is a multidisciplinary scientific and technological domain related with the increase of work situations in order to have better health, comfort, insurance as well as productivity [40]. In a general way by studying the ergonomics of a system we want to optimize the human interaction, promote security health and well being aswell as improving operation efficacy.

In [41], Poland a good computer workstation is characterized by having a proper work equipment, proper spatial organization together with proper position during work and proper work environment. In this thesis the GCS workstation will be very similar to a computer workstation. Regarding the desktop dimension, it should be at least 100 x 80 cm underlining that what is important here is the height of the desktop. The chair should have height adjustments in the range of 40 to 50 cm, equipped with armrests also with height adjustment. Footrests may also be necessary. The displays screens should be chosen according to the size of the characters on the monitor. Readability and sharpness of the image shall be provided according to several parameters, namely: contrast above 1000:1 and brightness minimum of  $250cd/m^2$ .

The spatial organization depends on the operator height, weight and length of their limbs. From that study we can point out several important principles to be followed when designing a computer station, also illustrated in Fig.3.8:

- The height of the chair and the height of the desktop should be adjusted so that the keyboard is located at the same level of the elbow;
- the chair adjustments should provide flexible angle in the knees and hips around 90 to 110 degrees.

In addition, the back of the chair should be placed so that it touches blades and adheres to the lumbar spine;

- the monitor should be located approximately 60 cm and positioned in a way such that the top edge is at eye level;
- the wrists should be able to rest on gel pads and the forearms should rest on the desk or armrests.

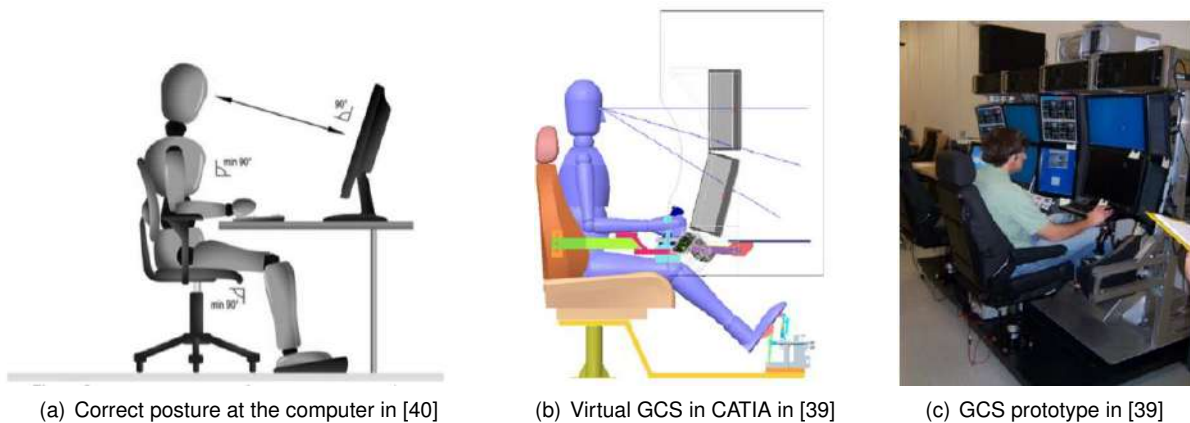

Figure 3.8: Cockpit examples

Besides that, to ensure proper working environment conditions the room should have access to natural light with the possibility of adjusting its intensity. Also, the monitor should be placed in a way that the reflections and possible high contrasts do not affect the visual work conditions.

### 3.3.3 Others

As stated in Sec. 2.2.1, the crew training represents a key aspect to the success of operation of the UAS. The creation of a Manual Guide is crucial for the user to know how to operate the GCS.

In addition, simulations and training sessions shall be performed before any attempt to fly a UAV with this GCS. In fact, there is a quite easy solution that Ardupilot support: software in the loop Simulator benefits from the fact that the Ardupilot is a portable autopilot that can run on a very wide variety of platforms. This can be accomplished by installing the simulator on a Linux OS for instance. When running the simulator like this, the sensor data comes from a flight dynamics model in a flight simulator. A wide range of vehicle types can be chosen - multi-rotor, fixed wing aircraft, underwater or ground vehicles - giving the trainee virtual experience on the particular vehicle required in the future missions.

To avoid fatigue and stress on a single operator, two operators shall be put to work on long range missions which require long periods of concentration.

In order to minimize the number of tasks per operator and to maximize fail safe, redundancy of systems shall be installed. That is, the implementation of two operator seats. Furthermore, each seat shall be able to fully control the aircraft and monitor all systems of the UAS.

It should be noted that, when performing long duration missions risk assessments shall be made taking into consideration not only the UAS itself, but also the environment and the personnel well-being.

## **3.4 Cost**

Last but not least, the Cost factor is one of the constraints to take into consideration when designing and building the GCS. This work serves the purpose of finding what is the best solution minimizing the cost as well as satisfying the imposed requirements.



# Chapter 4

## System and Components

In this section, the GCS systems and components will be scrutinized to its lower level explaining how the systems interact with each other, the electrical connections and its communication protocols with the intention of making it clear how exactly this GCS will be composed of.

### 4.1 Main Systems

From a general standpoint, we can divide the GCS into four main systems as illustrated in Fig. 4.1.

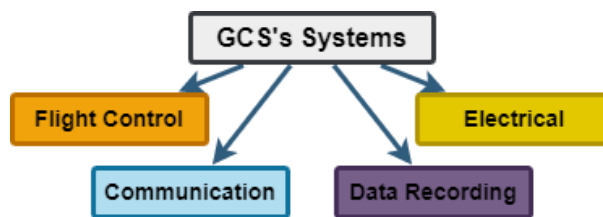

Figure 4.1: Four main systems in the GCS

#### 4.1.1 Flight Control

The Flight Control system is responsible for the controllability of the aircraft in every stage of autonomous flight, including take-off, climbing, loiter, trajectory following, descent, hold and landing. Through this system, the operator must be able to control, monitor and send commands to the aircraft. This system is composed of: the computer, the screen displays, the Mission Planner software and the radio control as showed in Fig.4.2.

#### Computer

The computer subsystem can be a wide variety of devices, from a tablet or phone to any desktop platform. It can be any device with an Operating System (OS) installed and is where the GCS software will be running.

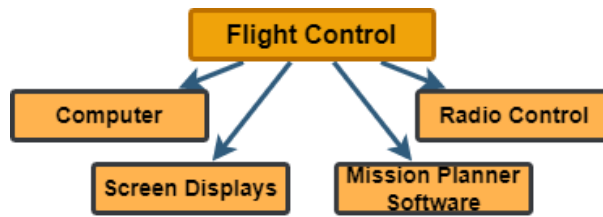

Figure 4.2: Flight Control Sub Systems

From a system architectural standpoint, the computing solution to be used should have a vast list of interfaces such as HDMI for connecting screen displays, USB to connect the radio module, keyboard and mouse as well as a joystick for manual remote control, Ethernet and WiFi for Internet access.

### Mission Planner Software

Mission Planner is the most featured GCS software supported by ArduPilot [33]. It acts as an instrumented panel displaying many of the instruments available in a real aircraft cockpit.



Figure 4.3: Mission Planner Interface

In Fig.4.3 is the window of the latest version of the software is available at the manufacturer webpage [33] and the installation is very straight forward.

Through Mission Planner, the operator will be able to send commands to the UAV as well to the display of all the telemetry data that are received through MAVLINK communication protocol which is explained in detail ahead. It is also possible to define waypoints on the map so the UAV can follow them automatically. Furthermore, there is the possibility to change the mode to override autopilot commands. To perform manual flight with a joystick input.

## Screen Displays

In order to have a visualization of the Mission Planner software, a screen display is necessary. Accordingly to Sec.3.3.2, the specifications to take in consideration here is the interface, brightness, contrast and its size. The interface needs to be either HDMI or VGA. The brightness and contrast needs to be superior to  $250cd/m^2$  and 1000:1 respectively. Finally the size should be one that could fit in the trailer.

There are several possibilities for displaying the information. There could be multiple monitor screens or a single large screen.

Regardless of the option for each operator system, four displays shall be shown during operations: one window showing the Mission Planner software, one showing the field of view (FOV) camera on board the UAV, one showing the camera installed on a gimbal for instance and, finally, one showing not only the commercial air traffic but also the weather map of the region.

## Radio Control

According to Rodrigues [9], it is enough for the LEEUAV flight control system to have an 8-channel radio controller to handle all the functionalities of the aircraft: throttle, ailerons, rudder etc.

This kind of radio controllers use a form of Digital modulation [42] called Pulse-Position Modulation (PPM) in which information is encoded in a stream of bits. More about this topic on the next section.

Beyond that, this radio will serve to control the UAV manually with a system that is entirely independent from the computer and the Mission Planner. Typically, these radio transmitters have their own battery which makes it even more reliable to power failures or any other system failure.

### 4.1.2 Communication

This subsection will be mainly about the topics in Fig. 4.4. There are several methods to send and receive data in UAS. The data exchanged between the GCS and the UAV can be commands, telemetry data or/and video. In order to have that exchange of information, radio frequency transceivers and antennas are used along with communication protocol that makes possible the data transfer and its interpretation. MAVLINK and PPM are just a few.

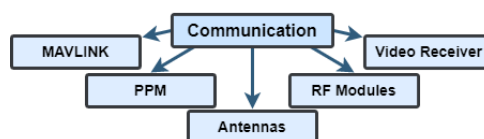

Figure 4.4: Communication Subsystems

## MAVLINK

The Mission Planner software features its own communication protocol called Micro Air Vehicle Link (MAVLINK). It is a communication protocol for unmanned systems, where each packet consists in a stream ranging between 12 and 280 bytes which contains the data to be sent, as seen in Fig.4.5. Other than that, the packet also contain information about its length, some flags for compatibility issues and packet loss, the system and component IDs, the checksum value and its signature. This brings serious advantages that together with Mission Planner turns the system more reliable, secure against any kind of hacking attempt.



Figure 4.5: Mavlink packet format [32]

Furthermore, there is a wide range of possibilities using MAVLINK such as manual flight in a more secure way that common radio transmitter cannot achieve, video transmission without the need of any extra antennas neither video receivers and recorders. MAVLINK has a video library that supports video messages and once they arrive your computer through a serial COM port it is easy to save them in the computer memory, or even to display them on screen so we can have live video from a camera on board for instance. Besides that, it also allows the control of any kind servos onboard the UAV. That means the operator can override the autopilot at anytime to fly the UAV manually.

In addition, a servo system to control a gimballed camera for example could be installed and controlled from the GCS.

That is all done trough Mission Planner Software on the computer without the need of extra hardware beyond a radio receiver capable of transceiver serial data over a COM port.

Nevertheless, a more archaic solution for the video system as well as the manual control of the UAV will be implemented for redundancy reasons.

## PPM

Pulse position modulation (PPM) is a signaling format in which the temporal positions of pulses are modulated by a message. This technique uses pulses of fixed width encoding the information to be sent in the delay between pulses, this way varying the position of each pulse.

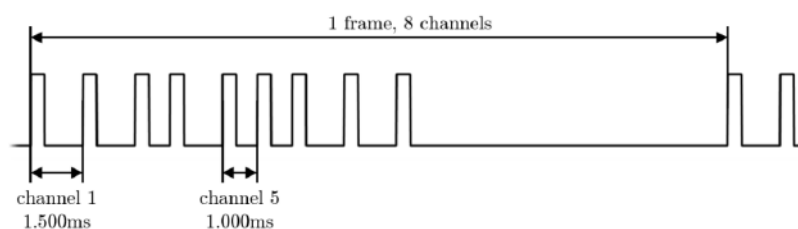

Figure 4.6: PPM signal outputted by an RC transmitter [43]

Usually one frame can contain up to eight channels with 20 ms length depending on the manufacturer. In the example presented in Fig.4.6, channel one has a value of 50% while the fifth has a value of 0%. These values typically represent the amount of stick deflection of the transmitting radio controller.

## Antennas

In what concern the antennas used, they are picked taking advantage of the geometry based on the frequency of the wave as well as its wave length. According to Miller [5] antennas can be divided into four main groups:

- **Monopole** - vertically erected and vertically polarized. It requires a receiving antenna to be similarly polarized and its radiation pattern looks similarly to a donnut having gains up to 2dBi;
- **Yagi-Uda** - with only one active dipole element, it comprises by a set of passive elements that turn the radiation into predominantly directional reducing the side-lobe radiations as it can be seen in Fig.4.7(a). These antenna have high gains up to 23 dBi;
- **Parabolic** - it is a dish in a form of a parabola transforming the radiation predominantly directional as the Yagi antenna presented in Fig.4.7(b). Its gain ranges from 30 to 70 dBi;
- **Square Patch** - it produces a beam with equal width in vertical and horizontal directions.

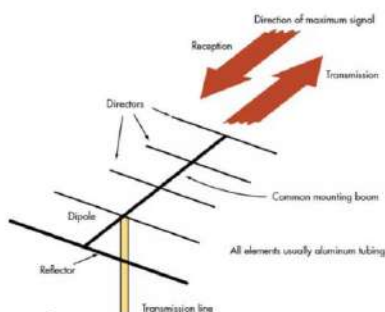

(a) Yagi Antenna Communication in [44]

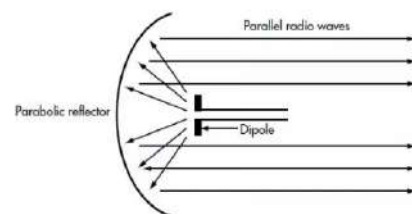

(b) Parabolic Antenna Communication in [44]

Figure 4.7: Yagi and Parabolic working principle

In order to better describe the performance of antennas, Miller [5] takes into account three fundamental aspects:

- **Antenna Bandwidth** - it corresponds to the range of frequencies in which the antenna is able to operate efficiently. So the antennas used have to be inside of this range;
- **Antenna Polarization** - it is basically the spacial orientation of the electromagnetic field. That can be affected by the antenna and there are three major polarization types namely: linear, circular and elliptical as seen in Fig.4.8. Better communication link is achieved if the same polarization antennas are used for both transmitter and receiver;

- **Gain** - it is a quantity of how much the radiation is concentrated into the desired direction in relation to the isotropic radiation factor. With the help of various either passive or active elements, antennas can reflect the radiation to a certain direction and thus improving the irradiated power in that direction, therefore increasing the distance of propagation.

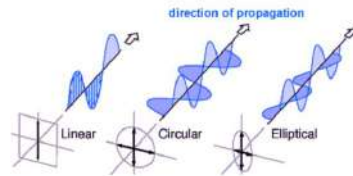

Figure 4.8: Different types of polarization [5]

## RF Modules

Having all the necessary tools to define a successful radio frequency (RF) communication explained in Sec.3.1.3, it is possible to estimate the parameters that would turn communications possible in the desired range as well as calculate that range.

Radio modules are characterized along with other parameters by its transmitting power gain on the side of the transmitter and by its sensitivity or receiver gain in the receiver side. Taking that into account and using the equations in Sec.3.1.3, the range of communications will be studied.

In what concerns the frequency used and looking at Eq.(3.2), clearly we see that it is preferable to maintain the RF chosen as low as possible to minimize the FSPL (considering a constant gain at any given frequency) and, consequently, maximize the RF link distance. In addition, accordingly to the data withdrawn from Miller [5] and with ANACOM [45], 433MHz and 868MHz can be used for amateurs and local radio applications. Furthermore, substituting those frequencies

$$\lambda = \frac{c}{f} \quad (4.1)$$

where  $c$  is the speed of light and  $f$  the frequency used, it is possible to calculate the wave length  $\lambda$ , resulting in  $\lambda$  equal to 0.69m and 0.345 m, respectively.

On the other hand, typical radios used for this kind of applications range in the order of milliwatt up to 5 watt of output power due to legal limitations [46]. Taking that into consideration, and assuming that the gains for Monopole, Square Patch, Yagi-Uda and Parabolic antennas are 2, 5,9 and 13 dBi, respectively, the range is calculated and plotted in table Tab.4.1, using Eq.3.4, assuming all the other variables constant.

Table 4.1: RF link distance between transmitter receiver for 433MHz

	Monopole	Patch	Yagi	Parabolic
Frequency [MHz]	433	433	433	433
TX Power [W]	0.5	0.5	0.5	0.5
Sensitivity[dBm]	-113	-113	-113	-113
RX Gain [dBi]	2	5	9	13
TX Gain [dBi]	2	2	2	2
Fade Margin [dB]	20	20	20	20
Calculated Range[km]	138.2	275.7	692.6	1739.8

Table 4.2: RF link distance between transmitter receiver for 868MHz

	Monopole	Patch	Yagi	Parabolic
Frequency [MHz]	868	868	868	868
TX Power [W]	0.5	0.5	0.5	0.5
Sensitivity[dBm]	-113	-113	-113	-113
RX Gain [dBi]	2	5	9	13
TX Gain [dBi]	2	2	2	2
Fade Margin [dB]	20	20	20	20
Calculated Range[km]	68.9	137.5	345.5	867.9

Observing Tables 4.1 and 4.2, it is possible to conclude that the range is clearly affected by the antennas used. Yagi Antennas typically have more gain than other antennas and therefore resulting in higher achieved range. For the Scherrer Long Range Systems that have a sensitivity of  $-113 \text{ dBm}$  and transmitting power of  $26.99 \text{ dBm}$ , the calculated range is about 69 km for a RF link between two monopole antennas, while using an Yagi antenna the ranges is considerably increased. Higher antenna gains results in higher RF link distances.

From Tab.4.1 and 4.2 it is possible to conclude again that increasing the frequency results in smaller RF link distances, for constant gain.

## Video Receiver

The video Receiver is part of the Video System of Miller's thesis [5] work in which he uses Commercial Off-The Shelf (COTS) products to broadcast video image from onboard cameras to the GCS. This system is comprised by the video camera, video transmitter and receiver, On-screen Display (OSD) and a digital video recorder (DVR) along with antennas as can be seen in Fig.4.9.

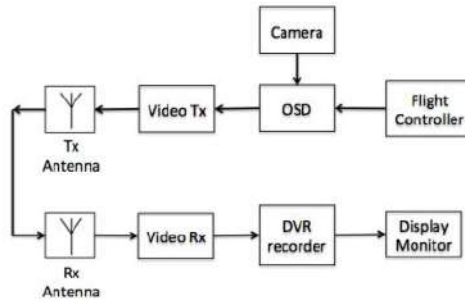

Figure 4.9: Scheme of the video system [5]

The objective of this system is to have image from a gimballed camera or from a fixed one. Either way the video is transmitted over the air through its own antenna in a different frequency of the RF modules above.

Nowadays, MAVLINK protocol supports video packets which means that this video system could be eliminated from the solution turning way simpler the architecture along with less systems and less failure options, nevertheless it can act as a redundancy.

### Data Recording

Data mostly enters the GCS through MAVLINK and via Human Interface. Either way it goes through the computer which has its own memory RAM in which data logs can be created. Managing the data of different flights and missions represents an important factor to the success of the mission. Besides, a cloud saving algorithm should be implemented to periodically save data in an online data storage. That ensures that in a power failure scenario or any other failure the flight data is recorded and accessible in case of all the systems shutdown.

In addition, the analog video receiver system saves its images directly to an SD card. This enables the easiness of taking out the images from the GCS to any other device by simply taking out the SD card from the SD card reader.

### 4.1.3 Electrical

In order to power up the GCS and all of its systems, electricity shall be fed into the trailer. Power failures are likely to occur and shall be mitigated with redundant components along with a good cable management to ensure reliability. There are a few solutions for power sources that are described below such as solar panels, batteries, uninterruptible power supply (UPS) and fuel powered generators. Furthermore, the power system architecture is presented in this section.

- **Solar panels** - as seen on the LEEUAV itself [9] the average power that the solar cells can produce is a maximum of 4.3W (per cell) with an average 1000W/m<sup>2</sup> of solar irradiance. By projecting half of the trailer to be covered with solar cells and taking into account the trailer rooftop dimensions, 2.8m<sup>2</sup> would be the available area to cover with solar cells. That means that using the same cells



that are used in the LEEUAV, 179 cells would fit onto the rooftop of the trailer. Accordingly to the datasheet of the C60 SOLAR CELL from SunPower [47], each cell has approximately  $156.25\text{cm}^2$ . Calculating the total power amount produced by the cells yields 769 W. It is a reasonable value that could help to save fuel and the environment but its disadvantages bring more problems and logistics compared to their advantages. For instance, if it is summer time during a mission it is desired to park the trailer on a shadow of a tree, for example, because of the summer hot temperatures. In addition, solar cells only maintain their nominal efficiency if they are regularly cleaned. That means having to take trailer to a car wash and having to wash the rooftop of the trailer before any mission. Finally the total amount of power produced by all the 179 cells would not substitute the fuel power generator, adding in this way, more systems and more complexity to the GCS to be built.

- **Batteries** - to be redundant to all the rest, several or a battery capable of endure the full mission shall be implemented.

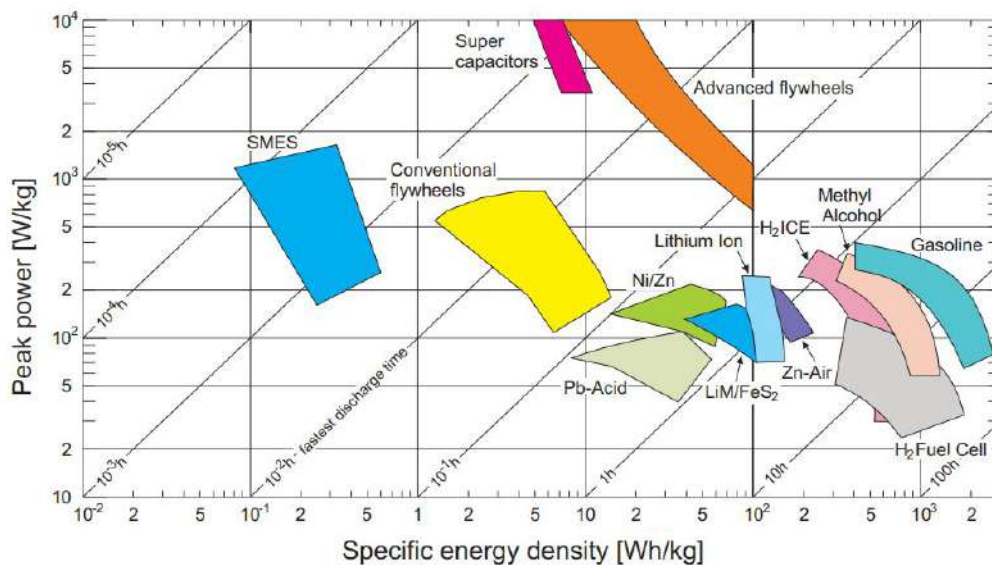

Figure 4.10: The Ragone Plot - Peak power and specific energy density of various energy storage methods [5]

In Fig.4.10, we are able to see several methods to store energy and its density relative to mass. For instance, it can be seen that discharge rate of Lithium Ion batteries two times better than Lead-Acid, lasting longer than others. In another study [48], it is said that both are the most widely used battery types for stationary storage in power system applications. The study compares both batteries in four main aspects: efficiency, life cycle, charging/discharging performance and cost analysis. A battery's efficiency is defined as the ratio between discharge energy and charge energy. In what concerns this parameter, Li-ion batteries show ratios nearly 100% whereas Lead-acid batteries range up to 75%. Regarding the life-cycle, number of charge/dicharge cycles, once again Li-ion batteries beat the lead-acid. The first ranges from 12 to about 25 years depending on the state of

charge, which translates to the amount of charge left over in the battery to avoid over discharge. On another hand, the Lead-acid ranges from 2 to 5 years. In what concerns performance, accordingly to the source, it depends on the discharge rate. For lower discharge rates, the lead-acid batteries beat the Li-ion while for higher discharge rates the li-ion present a better performance. In addition, Lead-acid are suitable to extreme operational temperatures than Li-ion, both extremely high and low.

Finally, in the cost analysis, the Li-ion end up to be the winner once again. Even though the cost per kWh is cheaper in lead-acid batteries than the li-ion, if we divide the upfront cost over the energy stored times expected operational life time, the price of energy is often several times less for Li-ion than lead-acid batteries.

Looking into another source of energy, fossil fuels are relative far from conventional batteries having even more energy per kilo-gram and that will be discussed ahead in this section.

- **UPS** - Uninterruptible Power Supply can give an extra redundancy to the GCS power supply. In addition, according to [49], an UPS delivers continuous electric power and protect connected loads from sudden power failure, over voltage, suppress line transients and under voltage.

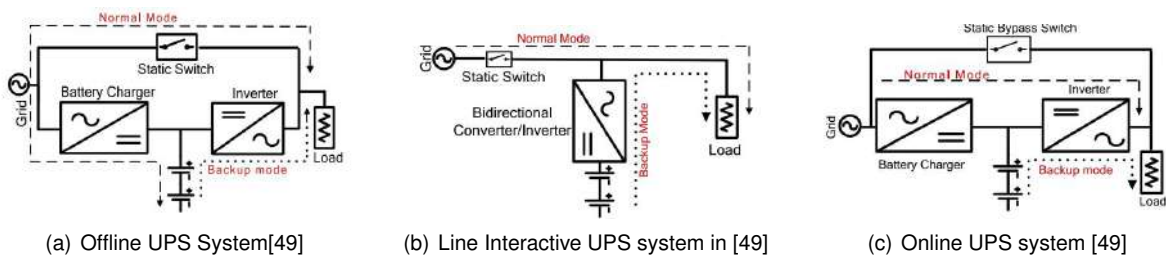

Figure 4.11: Different UPS types

UPS are classified as Offline UPS, Line Interactive UPS and Online UPS depending on the topological configuration. An offline UPS consists of a battery charger, a static switch and an inverters as it can be seen in Fig.4.11(a). During operation the charger will charge the battery bank and at the same the load is being powered by the main AC line. The inverter is turned off during this mode. When there is a power failure, the static switch connects the load to the inverter and the power is fed by the battery through the inverter. The switching time can be up to 10 ms which does not affect the normal computer load. Although its performance is very poor, adding to the fact that there is no real isolation from the load neither a voltage regulation, its advantages are the low cost, small size and simple design. They typically are suited for smaller loads of about 600 VA.

The Line Interactive UPS comprise a static switch, a bidirectional converter/inverter and a battery bank as can be seen in 4.11(b). When in normal operation, the main AC line powers the load while the converter/inverter charges the battery. When a grid failure occurs, the converter/inverter starts feeding the load. Its advantages can be the low cost, small size and high efficiency. Its disadvantage is not providing any voltage regulation. Suited for applications rated between 0.5 kVA and 5 kVA, the Line interactive UPS performs very efficiently, usually above 97%.

Finally, the Online UPS comprised by a rectifier, an inverter and a static switch shown in Fig.4.11(c). Same as the previous, it charges the battery in normal mode of operation. The addition here is that it provides isolation between the load and the grid providing protection against spikes or any variation of the harmonics on the grid. The major disadvantage is that the Online UPS is very inefficient. Is typically suited for applications above 5 kVA.

In conclusion, the best suited for our trailer is the Line Interactive providing power reliability and high efficiency while costing a small volume.

- **Fuel Generator** - although it is not environmentally friendly it is a reliable power source that when filled with the required fossil fuel can be power a variety of different batteries and devices.

According to [50] a diesel generator is the blend of a diesel motor with an electric generator (regularly an alternator) to produce electrical energy. This is a particular instance of motor generator. A diesel pressure start motor frequently is intended to keep running on fuel oil, yet a few sorts are adjusted for other liquid fuels or natural gas. Diesel generating sets are utilized as a part of spots without connection with a power grid, or as emergency power-supply if the grid fails or even to be the principal main power source in UAS applications such this GCS.

To conclude this section, it is presented in Fig.4.12 the power system architecture that will be implemented to ensure redundancy, reliability and control over the different sources. With the implementation of switches, it is possible to control and choose in a manual way what is turned on and what is not.

From an operation point of view, preferably the generator is used as main source of power, having a differential switch satisfying the standards of the International Electrotechnical Commission in order to ensure safety of humans in case of short circuit. Both generator and grid sources have this protection. Then a source selector is added to give the possibility to switch between sources manually and safely. A double power converter is chosen to emulate an online UPS system.

The power distribution is divided between essential components and non essential components. Having two different working voltages, the distribution is described in Fig.4.12, as Non Essentials@230VAC, Non Essentials@12VDC, Essentials@230VAC and Essentials@12VDC. This way it is specified what should be turned on during normal operation in case of power failure.

In addition, the operator can, in any instance (before, during or after the mission) be able to disable manually individually each segment through switches A, B and C. They can be turned on and off whenever is necessary.

In case of an eventual malfunctioning or shutdown due to any cause, only essential systems are turned on to maximize the duration of the battery and consequently the operation in course. A Voltage Sensor is used to continuously measure and broadcast the voltage of the battery to the human interface enabling an alert whenever the voltage across the battery terminal is low.

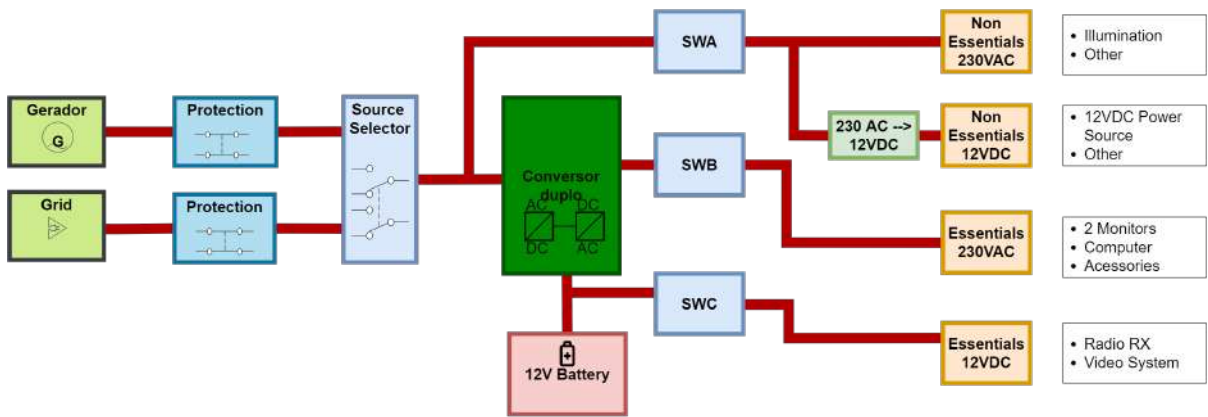

Figure 4.12: Power System Architecture

Since it can be possible for the trailer to be powered by multiple power supplies, a device capable of switching between two AC sources without power interruption and over voltage is required. These are called changeover transfer switches and, if they comprise a mechanism that makes them switch automatically whenever there is a power outage, they are called an Automatic Transfer Switch (ATS). They are categorized accordingly with their working principle which can be observed in Fig.4.13

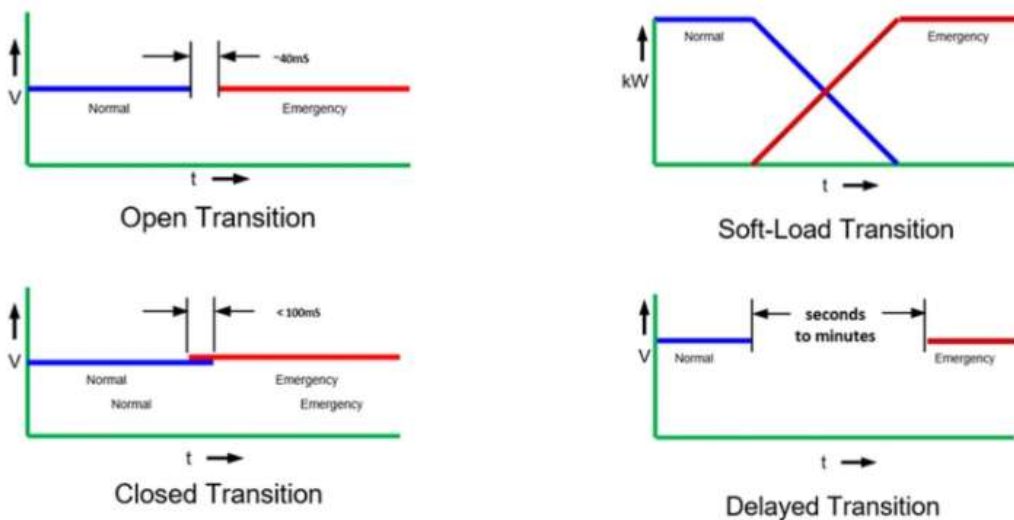

Figure 4.13: Automatic Transfer Switch Modes [51]

Open Transition switching can be also referred to as "break-before-make". There are two types of Open Transition switching: open delayed and open in-phase. When having a delay between transition can prevent to inrush current that can damage systems when power sources are not synchronized. In this transition process, the load will experience a brief power interruption which is good if we have critical systems that are always required to be powered up. The open in-phase transition includes an automatic controller with built-in intelligence making the execution of transition at the precise moment it expects the normal and emergency power sources to be synchronized in phase preventing the in-rush current.

At least 150 milliseconds [2] are required to complete the process which is too high and the load can suffer the power outage anyway in some cases.

The Closed Transition Switching is the one that perhaps can suit our application in which we want to alternate between power sources without interruption of power. This process can be referred as "make-before-break" in contrast to the open transition switching. This results in a momentary source paralleling that if there is no synchronization between the power sources can damage the systems. Closed Transitions can be classified in three types: Active, Passive and Soft Loading. In an Active switch, a special automatic synchronization switch is used to control the switching resulting in an efficient power transfer. On the other hand, in a passive switch a synchronization check relay is incorporated, which only allows the two contacts to close when the two sources are in synchronization. The advantages of these type of devices are obvious but usually come with associated cost.

In our case, since that during mission it is not required to change between sources, an inexpensive open transition between sources would be satisfactory. It should be mentioned that this feature will be only used during testing in order to safe fuel.

## 4.2 System Architecture

At this point, every aspect and feature that a GCS shall have been introduced and explained. In Fig.4.14, the GCS system architecture is presented. As a general overview of the different systems and how they interact with each other.

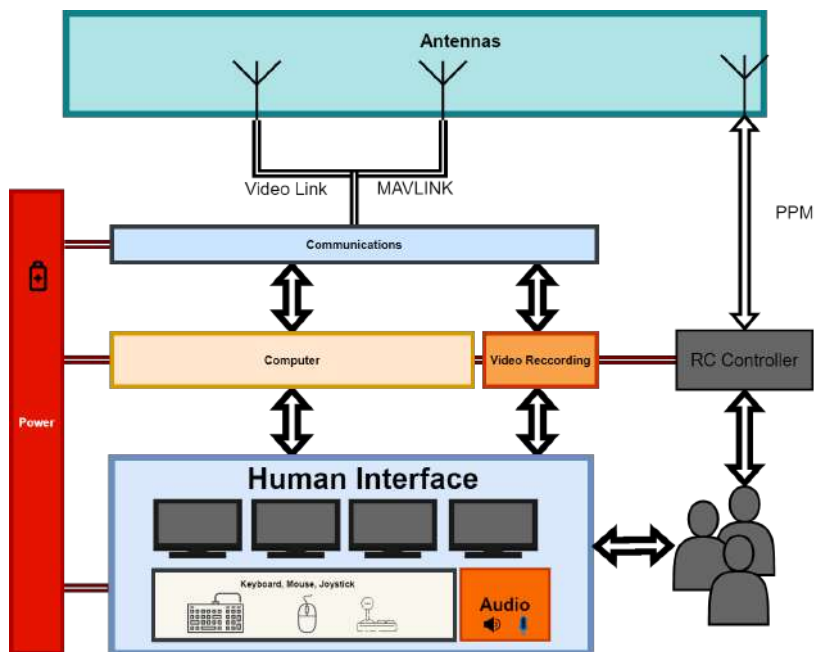

Figure 4.14: GCS System Architecture

The main systems are :

- Power system - designed to power all systems and had previously explained in Sec.4.1.3 ;
- Communications, antennas and video recording - is the hardware responsible to broadcast and receive, through electromagnetic waves, the commands and telemetry between the GCS and the UAV as well as to receive and record the analog video stream;
- Computer - Runs the Mission Planner and acts like a telemetry recording system;
- RC Controller and Human Interface - where the operator can give inputs to the GCS and control either manually or through actions the UAV.

As the operator uses Mission Planner which runs on the computer, the commands are introduced through mouse and keyboard. These are interpreted by the Mission Planner, encoded into MAVLINK packets and sent over a serial COM port - just a USB cable connected to a USB port - which in turn are received by the RF transmitter and modulated into Frequency shift keying (FSK) modulation. The radio then transmits this analog signal onto the coaxial cable to the antenna which then emits the electromagnetic wave onto the UAV.

For the RC controller, the operator controls the UAV manually giving inputs by simply adjusting the joystick in the controller. The percentage of the movement of the joystick is encoded into PPM packets and sent through the transmitter.

The video System is comprised of a RF receiver and an SD card video recorder. The video image arrives the GCS in format PAL and is then recorded in the SD card.

Every system can be turn on and off independently through the human interface through a central panel which will be explained ahead in this document.

## 4.3 List of Components

In this section, the main hardware components of each system are presented, along with their relevant characteristics and specifications, starting with the power system in which the different possible power sources are presented. In addition, the protection and control hardware is presented.

Furthermore the communications system – radio frequency transceivers and antennas – is introduced as well as the RC controller and the video systems – both transmitter and receiver, for RC and video systems – are introduced too.

Finally, the human interface is presented along with its features and functions.

### 4.3.1 Power

Every system needs energy to work properly. As there are many systems and components, different power sources maybe required, as well as a continuous, without interruption, power feeding.

Control and protection against any shortages or malfunctioning are also one of the requirements to be implemented.



Figure 4.15: Power system components

### Power Sources

Because of different systems working either with 230 VAC or with 12 VDC, different power sources are required.

**Fuel Generator** - this is a 2000W power generator feeding a 230VAC mono phase signal into the power line, Fig.4.15 . Comprising a voltage stabilizer with thermo protections in order to provide a clean and steady power supply and, in case of fire, to shutdown immediately.

It requires gasoline to work and it consumes about 0.75L/h, having an autonomy for at least 4h between refueling.

**12V Lead Battery** - to ensure power reliability and endurance this 180Ah battery can last at least 8 hours during operation ensuring that the GCS and all of its essential systems are fully operational, Fig.4.15.

**Double Converter** - this device, Fig.4.15, performs double conversion of the supplied power. It requires to be fed with 230AC signal and converts it to 12VDC in order to safely continuously charge a battery. This power is then converted again into 230AC. This way, there is no gap of energy supply in the load when the main power supply is off, ensuring the continuous power supply just like an online UPS.

### Protection and Control

In order to protect the rest of the circuit, protection measures shall be taken. In addition, to enable the GCS to change between power sources and control the flow of power to each component or system individually, a set of switches shall be properly mounted and connected as explained in Sec.4.1.3.

**Hager CDC2250 Residual Current Device** - it is used as a measure of safety in electrical appli-

cations such as in building electrical installations and any other high voltage applications, Fig.4.15. It continuously monitor the current that goes into the load from source and compares it to what it leaves the load. If, for some reason, there is any short circuit or any fault that causes a difference in the current the device will turn automatically off the power supply preventing any damage of sock to humans. Typically this difference is about 30mA as required by the International Electrotechnical Commission standards.

**Hager SFB225 Changeover Switch** - it enables the switching between two distinct AC sources for instant Grid and Generator, Fig.4.15. When the "change over" or the switching happens all the power on the circuit changes from either Grid or Generator not allowing it to flow back into each other.

**Lever Switch** - In order to turn on and off the 12VDC devices and envisioning a control panel that will enable the activation of each system individually, this switch is used, Fig.4.15.

### 4.3.2 Video, Communications and Antennas

As the GCS must to be able to communicate at distance to the UAV, radio frequency receivers and transmitters along with its antennas have to be included for the different data transfers between GCS and UAV.

#### Mission Planner Radio Frequency Receiver/Transmitter

**Radio Transmitter/Receiver from 3DR Robotics** - these radios are used to establish a link between the computer and the UAV Flight Computer. Operating in the 433MHz frequency, Fig.4.16, they have an output power up to 100mW and a sensibility of -117dBm.



Figure 4.16: Telemetry Radio 3DR Robotics

#### Radio Control Frequency Receivers/Transmitters

**Scherrer TX 700 PRO UHF** - Capable of transmitting on the 433MHz, this radio module, Fig.4.17, can output PPM encoded commands to the UAV radio receiver enabling a manual remote control of the aircraft. According to [52] these radios enable communications up to 340 Km assuming antennas with 2 dBi.





Figure 4.17: Scherrer TX 700 PRO UHF

### Video System Components

**Partom 850mW 1.3Ghz Video System** - featuring eight channel this analogical video system, Fig.4.18 (a), transmits between 1.2 and 1.3 GHz .

The required video, power and antenna cable connectors and RFA male, power jack DC 2.1mm and SMA female.

**Oracle Video Diversity Controller** - The Oracle video diversity controller, Fig.4.18 (b) is used to bridge two wireless video receivers together. Dual receivers can be used to help reduce RF multi-path problems, as well as allow for other signal improving techniques.

**Mini DVR Support SD Card Real-time Digital Video Recorder** - mini DVR, Fig.4.18 (c), can be used to record any analog video that go to its RFA connector input. Easy to setup, it is only required an SD card and 12VDC to enable the video recording.



Figure 4.18: Video system components

### Antennas

**Antenna 1.3Ghz 3dBi Monopole antenna** - with an omnidirectional pattern, this 1.3GHz 3dBi Antenna, Fig.4.19 can receive and transmit analogical video when connected to the video system.

**A430S10 Base Station Yagi Beam** - with a gain of 13dBi, this antenna, Fig.4.19(b) can efficiently operate in the 430-440 MHz band. It will be used to transmit PPM commands to the UAV.

**Estrutura LH IberoStat 110LH Parabolic Antenna** - having the highest gain of all antennas this can be used for when the UAV is at a considerable distance. Having no constraints in terms of wave length, this antenna, Fig.4.19(c), can be used for different communications at different frequencies and polarization.

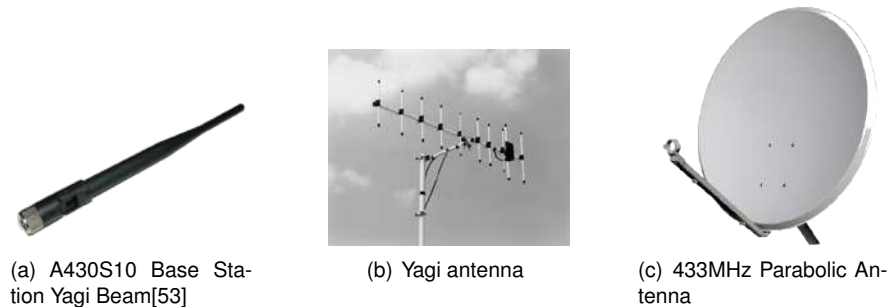

Figure 4.19: GCS's Antennas

### 4.3.3 Computer and Human Interface

#### Displays

**Monitor Asus VP229HE Screen Display** – ASUS VP229 is a 21.5 inch Full HD , monitor, Fig.4.20 (a) that features a frameless IPS panel for wide angle viewing to deliver incredibly sharp imagery and stunning video playback. Up to 75Hz refresh rate with Adaptive-Sync/FreeSync™ technology to eliminate tracing and ensure crisp and clear video playback [54].



Figure 4.20: Display Screens

**10.1 inch High Brightness Ground Station HD FPV Monitor** – Sunlight readable monitor with HDMI Video Input, designed for outdoor use, it is the best choice for fpv users, Fig. 4.20 (b).

### 4.3.4 RC Controller and Video Recording

#### RC Controller

**Transmitter Duplex DC-14 EX MM RC Controller** - The DUPLEX EX family of products, Fig.4.21, have been equipped with an improved real-time telemetry system which can be viewed on the LCD transmitter display. The transmitter allows the setup of voice notifications, both preinstalled and user

created, which can be related to telemetric values, user set alarms, or signals which have been assigned to conditions of various control elements.



Figure 4.21: Transmitter Duplex DC-14 EX MM RC Controller

It should be mentioned that all these components were chosen taking into considerations its specifications, its cost functionality and quality ratio. It was a compromise between these three.

#### 4.4 Eletrical Schematic

The electrical schematic is a very complex scheme of connections between the different components of the GCS. To begin with, a draft of the necessary interconnections and wiring between the different components and systems was done, Fig.4.22. While some wiring represent power, other symbolize the flow of data or video stream. From here, more drafts where made to think how spatially everything would fit together inside of the trailer. That is discussed later.

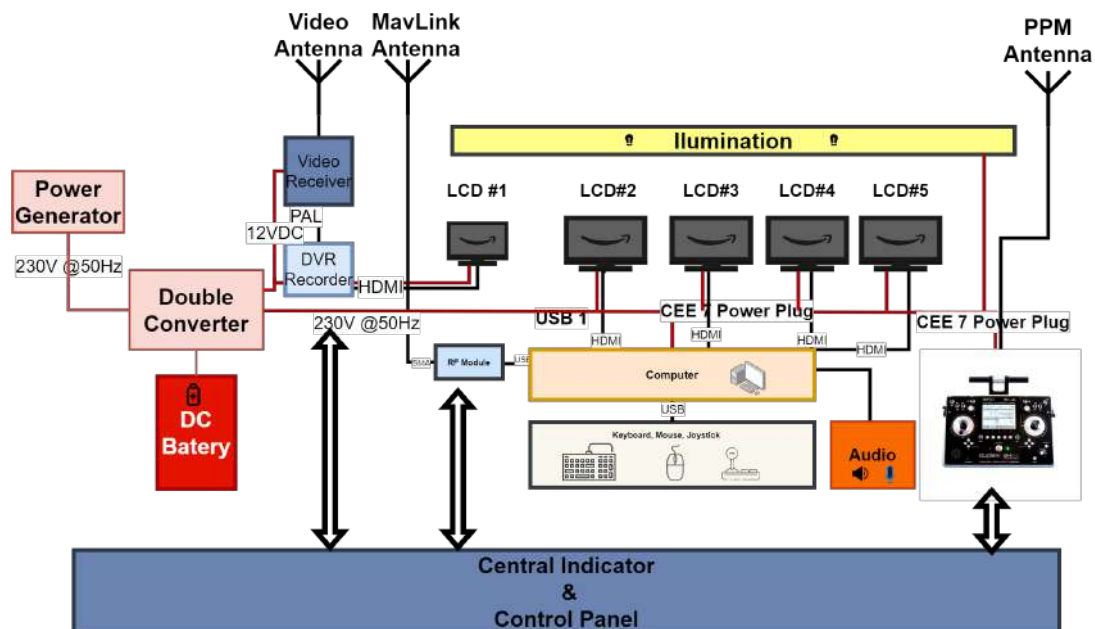

Figure 4.22: Electrical schematic draft

In a succinctly manner energy must flow from the power generator to the double converter. All that is essential and crucial to the success of the mission is powered by the converter to ensure that there is

no energy gap, in case of fuel ends up or any other power failure.

The video system requires 12VDC while everything else require 230VAC to work properly. The central indicator and control panel, as the name says will be a set of indicators and control switches to power ON and OFF each one of the systems.

Other connections that are not power connections are the video stream. Since it enters the GCS through the antenna of the video receiver, it flows to the DVR recorded and then is displayed on one of the LCDS. This is the analogical video system.

The commands and telemetry are exchanged via another radio. The telemetry radio 3DR is connected trough USB to the computer, therefore not needing any kind of power input.

In addition, attached to the computer there will be all the human interface components: mouse, keyboard, microphone and headphones and/or speakers.

Now, to better explain how everything is connected, the electrical schematic is divided into five groups: power supply, computer system, video system, radio system and other.

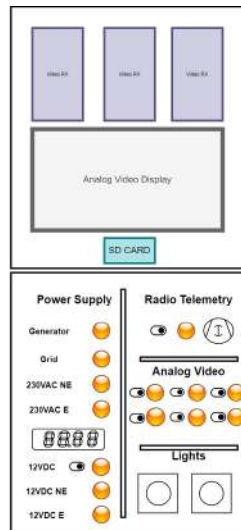

Figure 4.23: Central indicator and control panel concept

The central indicator and control panel concept was done. Somewhere in the center of the human interface, a panel of switches capable of turning on and off each system was envisioned, Fig.4.23

#### 4.4.1 Power Supply

Being able to be connected from any 230 VAC power source, the GCS has two different inputs for this: the grid input and the fuel generator input. Depending on which one is connected, a LED light pops up in the central panel. As the operator may want to change from one to another at any instance, a "break before make" switch is included in the network.

Then, the network is divided into four groups: Non Essentials@230VAC, Non Essentials@12VDC, Essentials@230VAC and Essentials@12VDC, each one of them has an associated LED that turns on in the central panel when its associated switch is turned on. Another LED is connected in parallel with the

battery to indicate that it is connected and feeding the Essentials@12VDC network. As can be seen in Fig.4.24, a double converter is included in order to continuously feed the Essentials@230VAC network.

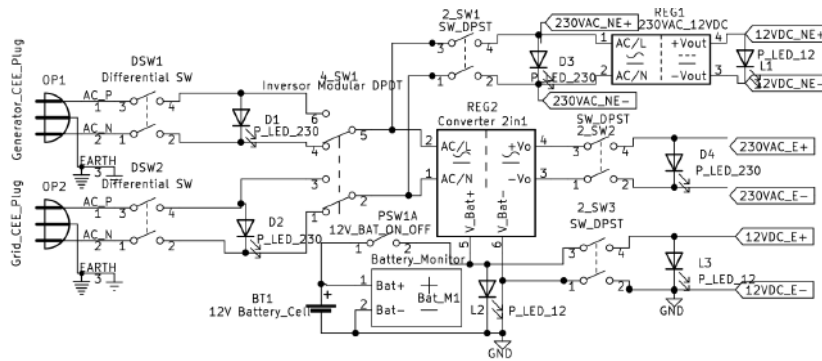

Figure 4.24: Electrical Schematic of Power Supply system

The rest of the systems are connected to this four main networks.

#### 4.4.2 Computer System

The computer system is comprised of the computer, four screen displays, keyboard and mouse and USB ports, Fig.4.25.

These are all components which are essential for the success of the mission, therefore, they are connected to the Essentials@230VAC grid. Meaning that if any power failure happens, they will stay on.

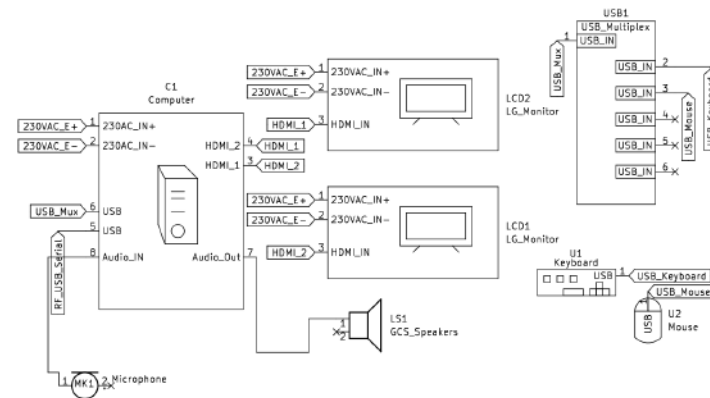

Figure 4.25: Electrical Schematic of the Computer System

#### 4.4.3 Video System

The video system is composed of two video receivers, an Oracle Diversity, an SD recorder and a ten inch LCD screen display. All of it is located on the upper central panel as it will be presented later on.

In Fig.4.26 several switches can be seen connected in series with the power grid that feeds them. These are lever switches which are meant to enable the operator to control its state from on to off and vice versa.

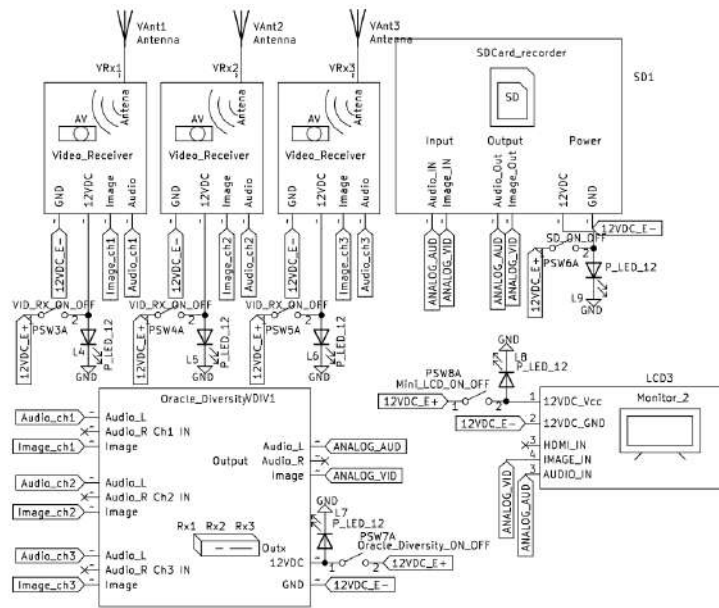

Figure 4.26: Electrical schematic of the video system

#### 4.4.4 Radio System

The radio system is very simple. It is just composed of it self and the antenna to be used, Fig.4.27. The SMA connector provides the ability to easily connect and disconnect any antenna that suits the operator right at the setup, before the mission.

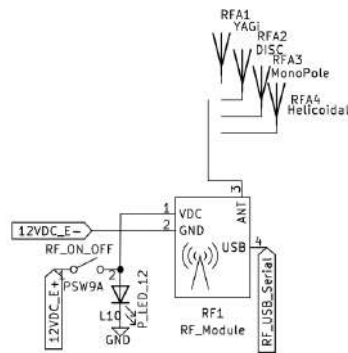

Figure 4.27: Electrical schematic of the radio system

#### 4.4.5 Other

Here are the lights and all other power plugs located all around the trailer. Since they are add-ons and are not relevant to the mission they are connected to the Non Essentials@230VAC power grid.

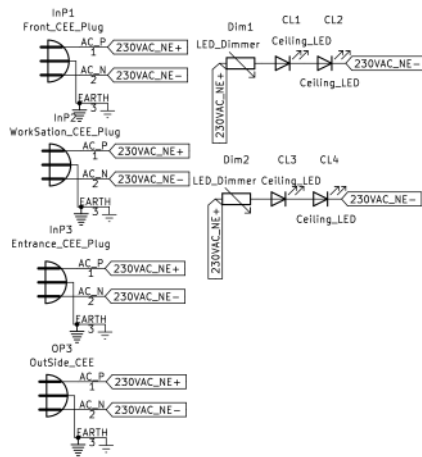

Figure 4.28: Electrical Schematic of lights and other

## 4.5 Power Budget

In Tab.4.3 Tab.4.4 is summarized the power consumption both for the 230VAC systems and for 12VDC systems, respectively.

As previously said in Sec.4.1.3 the GCS is divided into four different grids. As the generator can provide 2000W, this is the maximum value which cannot be exceeded. For the ESSENTIALS@230VAC there will be four LCD monitors, one computer and all its peripherals. Accounting also to a factor of loss, giving a safety margin of 120 W, the total power consumption is about 484 W.

Table 4.3: ESSENTIALS@230VAC systems power consumption

System	Qty	Component	Power [W]
Computer	1	Computer	300
	4	LCD	64
		Loss Factor	120
<b>TOTAL</b>			<b>484</b>

For the ESSENTIALS@12VDC it is considered a loss factor of 10 W. The included systems are the radio and video system. The total power consumption will be about 34 W.

Table 4.4: ESSENTIALS@12VDC systems power consumption

<b>System</b>	<b>Qty</b>	<b>Component</b>	<b>Power [W]</b>
Radio	2	RF_Module	4
	2	Video_Receiver	6
Video	1	SD_Card_Recorder	3
	1	Monitor_2	10
	1	Oracle Diversity Controller	1.2
		Loss Factor	10
<b>TOTAL</b>			<b>34.2</b>

Taking into account these power consumptions it is now clear that the 2000 W power generator will be enough to power this GCS. The operator can still make use of the extra 1400 W for personal laptops or any other devices that required electric energy.



# Chapter 5

## Layout

This section aims to show the conceptual design of the GCS along with its aspects and features in order to operate correctly.

### 5.1 Overview

In Fig.5.1 is what the GCS should look like when fully assembled and operational.

A power generator is shown connected to the trailer to power up the GCS. One of the two workstations as well the antenna system can be seen in this figure.



Figure 5.1: Ground Control Station

### 5.2 Operator Interface

The Operator Interface is what exchanges information between the UAS and the Operator. The operator shall be instructed with the manual and procedures list before operating this GCS to prevent any eventual accidents.



Figure 5.2: Operator Interface

In Fig.5.2 it is possible to see the rendered image token from Solidworks CAD software of the human interface panel. Marked with numbers are: 1 – LCD screen display; 2 – Keyboard and mouse; 3 – Central indicator and control panel ; 4 – Analog video system panel.

### **Indicator Hub**

The Central indicator and control panel is where the state of the different components is displayed ,Fig.5.3. Here the operator can know from which source the GCS is being powered. Furthermore, taking in consideration the definitions of Non Essentials@230VAC, Non Essentials@12VDC, Essentials@230VAC and Essentials@12VDC stipulated in Sec.4.1.3, is can be known the state of this power grids.

In addition every 12V component can be turned on and off individually from this panel. There is a lever switch connected in series with all the other, giving the possibility of turning on and off all at once.

There are also a few LEDs that are intended left unused to give space for more components in the future.

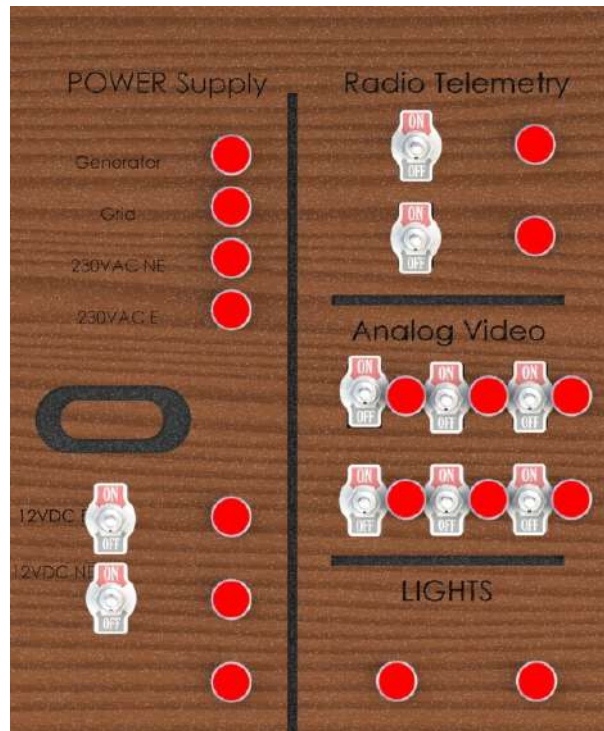

Figure 5.3: Central Indicator and Control Panel

### Electric central panel

This is where the Hager CDC2250 residual current devices, the Hager SFB225 changeover switch and the Hager SFB225 modular switch are located. This is the central panel for all the 230VAC grids. The energy first comes into here before flowing to the rest of the GCS, therefore, enabling safety and control over the different 230VAC systems.

## 5.3 Structure

The human interface panel is where the major components are located. Such components must be well fixed and in case of the LCD monitors, they have to be positioned with a tilt angle. Therefore, a structural assembly that holds the LCDs monitors, the central indicator control panel, the analogical video system was designed and conceived.

The assembly is composed of six pairs of glued MDF profiles as it can be seen in Fig.5.4(c). Four big MDF planks go through the six profiles: two at the center, side by side to ensure structural stability, and two to create the necessary distance and angle for the fixation of the LCDs. This way, the LCD screen position will be easy to adjust and align with its mdf front frame.

Moreover, thinking also on the cable management, the side perspective holes are for that purpose.

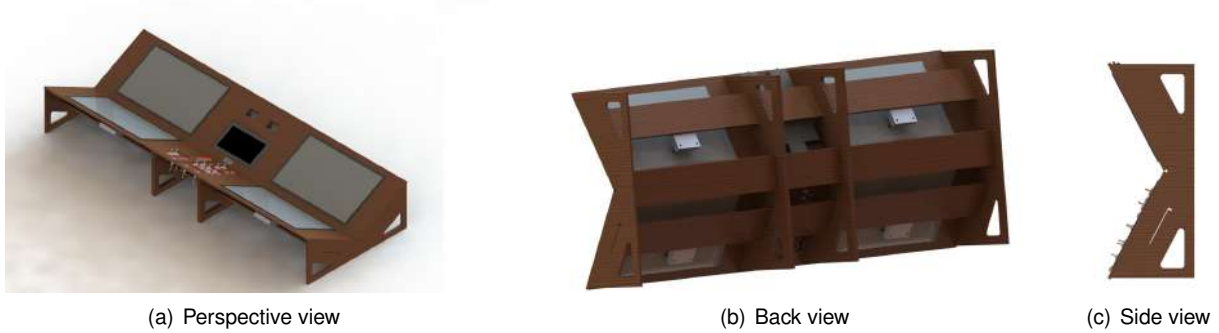

Figure 5.4: Assembled MDF structure concept model

## 5.4 Cable Management

Taking into account all systems and components described in previous sections, Fig.5.5 describes how spatially they will be connected and positioned.

Around number one will be both generator and grid power inputs. The double converter and battery will be there too. The wiring goes from one to three, where the electric central panel is positioned. The 230VAC switches are there. Furthermore, the illumination LED lights represented as yellow, are also connected between three and two. The intensity regulators will be near number one.

Near number two there is the central indicator and control panel where all the LED indicators are displayed, and consequently, connected between one and three. All the cables are meant to follow technical gutters.

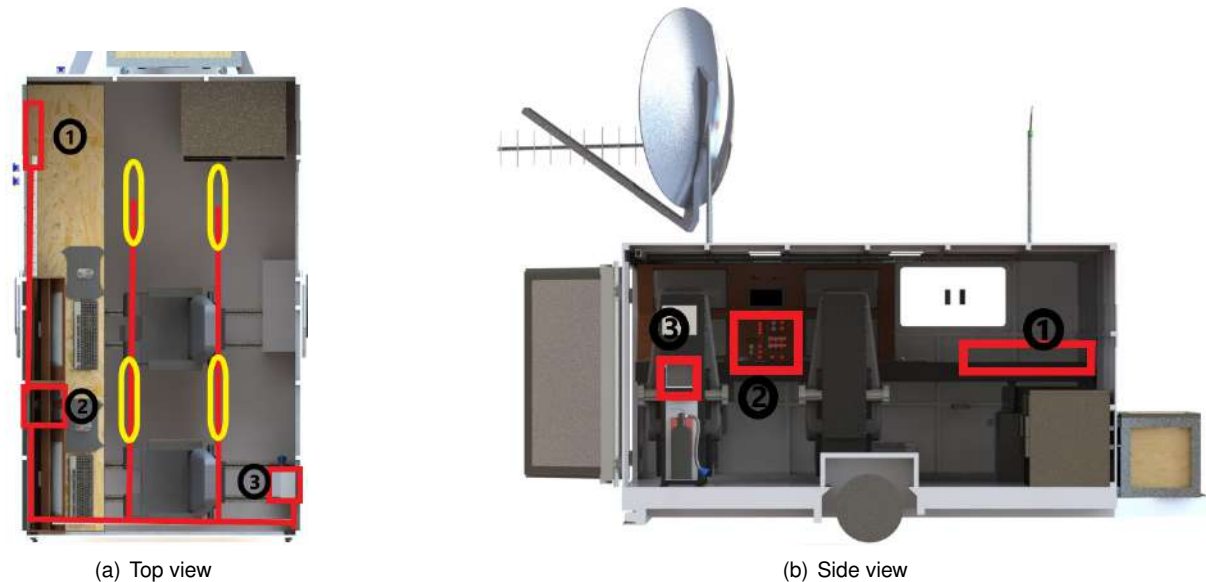

Figure 5.5: GCS's cable management draft

# 5.5 List of Materials

According to sections 4.4.1 to 4.4.5 the component list would come automatically from KICAD software.

## 5.5.1 Wiring

Looking at Fig.5.5 it is possible to estimate the necessary wire and their quantities. That is summarized in Tab.5.1 for the 230VAC and 12VDC together since the wire gauge chosen for all grids was the same.

For the 230VAC grids, the current flowing through the systems will not get higher than 16A. That means a wire gauge of 1.5mm<sup>2</sup> is enough.

Table 5.1: Required quantity of 230VAC wire

Item	Qty	From	To	Length
1	3	1	3	8 m
2	1	3	1	8 m
3	4	3	2	4 m
<b>TOTAL</b>				<b>48 m</b>

For the 12VDC systems, looking at Fig.5.5 (a), the distance between 1 and 2 is about 3 m. In order to know what should be the wire section area the drop voltage due to the resistance of the cable shall be considered. An online calculator [56] is used to ensure that the voltage drop is about 3%, as recommended. By filling the parameters in the calculator, at 12VDC, 3A, 1.5 mm<sup>2</sup> section wire and 3 m distance from the load it is concluded that the voltage drop is 2.5% below the required, therefore, meaning that a 1.5mm<sup>2</sup> section wire is good enough for this application.

## 5.5.2 Power Supply Components

Regarding the power supply components, Tab.5.2, it is necessary two different inputs, thus for that OP1 and OP2. To select which one is working, a change over switch is also included.

In this list is also the Differential SWs which ensures control and safety for all the 230VAC systems. The 230VAC indicator LEDs together with the 12VDC LEDs are also included here. Beyond that, the double converter along with some other switches – 2-DPST – are displayed here too.

Table 5.2: Power supply component list

Item	Qty	Reference	Designator	Description
1	2	OP1, OP2	Grid_CEE_Plug, Gen_CEE_Plug	Outside electric power inputs
2	2	Differential SW	DSW1,DSW2	Hager CDC225O residual current device
3	4	P_LED_230	D1, D2, D3, D4	230VAC indicator LED
4	1	4_SW1	Inversor modular DPDT	Hager SFB225 Changeover Switch
5	1	REG2	Converter 2in1	Kemot Conversor 12V ->220V 500W
6	2	SW_DPST	2_SW1, 2_SW2	Inversor Modular
7	4	P_LED_12	L1, L2, L3	12VDC indicator LED

### 5.5.3 Computer System

For the computer system, Tab.5.3, all that is necessary are the keyboard and mouse, the LCD screens and of course, the computer it self.

Table 5.3: Computer system component list

Item	Qty	Reference	Designator	Description
1	1	C1	Computer	Desktop computer with Windows OS
2	4	LG_Monitor	LCD1, LCD2, LCD3, LCD4	Asus VP229HE IPS
3	2	U1	Keyboard	Trust TKM 350 keyboard
4	2	U2	Mouse	Trust TKM 350 mouse

### 5.5.4 Video System

The video system, Tab.5.4 includes two video receivers – VRx1 and VRx2 –, one monitor – LCD3– an SD card video recorder and an oracle diversity controller.

Table 5.4: Video system component list

Item	Qty	Reference	Designator	Description
1	2	Video_Receiver	VRx1, VRx2	Partom 850mW 1.3Ghz
2	1	SDCard_recorder	SD1	Mini DVR Support SD
3	1	Oracle_Diversity	VDIV1	Oracle video diversity controller
4	1	Monitor_2	LCD3	10.1 inch high brightness ground station FPV monitor

### 5.5.5 Radio System

The radio system, Tab.5.5, includes the radio, This system can be further improved and augmented since the radio frequency outputs and inputs can be more than one.

Table 5.5: Radio system component list

Item	Qty	Reference	Designator	Description
1	1	RF_Module	RF1	Telemetry Radio 3DR Robotics
2	1	P_LED_12	L10	12VDC indicator LED
3	1	RF_ON_OFF	PSW9A	Lever Switch

### 5.5.6 Other

Here is all that is illumination and electric plugs, Tab.5.6.

Table 5.6: Other system component list

Item	Qty	Reference	Designator	Description
1	4	CEE_Plug	InP1, InP2, InP3, InP4	Socket 2P+T SCHUKO 16A 250V
2	2	LED_Dimmer	Dim1, Dim2	230VAC LED Dimmer
3	1	Ceiling_LED	CL1, CL2, CL3, CL4	230VAC Strip LED

### 5.5.7 Structural Material

In order to assemble the structure mentioned in Sec.5.3 the following list of MDF sections are required, Tab.5.7. Refer to the annex B.1 to visualize the respective drawings.

Table 5.7: Required MDF parts

Item	Qty	Reference	Designator	Description
1	6	TPx	TP1, TP2, TP3, TP4, TP5, TP6	Top profile 319x247x10mm
2	6	LPx	LP1, LP2, LP3, LP4, LP5, LP6	Bottom profile 319x247x10mm
3	4	Screenx	Screen1, Screen2, Screen3, Screen4	LCD frame 360x700x10mm
4	1	CPTx	CPT1	Central panel top 360x295x10mm
5	1	CPBx	CPB1	Central panel bottom 360x295x10mm
6	4	Px	P1, P2, P3, P4	Plank 1695x115x10mm

## 5.6 Implementation Plan

Once everything is sorted out, the implementation is the next step in the sequence of this work.

To get started, the power supply system will be the first to be implemented. But not all at once. The central electric panel shall be the first thing to be mounted with the illumination ceiling LEDs. As the implementation goes further the structural support will be required to support not only some of the components, but also to manage join all the wires in their place. In addition, the central indicator and control panel is necessary to hold all the LED indicators and lever switches. Along with that, the technical

gutters shall be mounted as well. As the process goes through, the turning on and off of the systems is required for the implementation and testing.

Once the structural profile pieces are manufactured they shall be assembled on the GCS with screws and "L" shaped joints to give an extra structural stability.

The fixation of the LCDs, electric plugs, the converter and battery shall be next and then the assembly of the 12VDC systems can be made, as well as their testing.

Finally, once everything works properly, the antennas shall be positioned and an overall test shall be made.



# Chapter 6

## Implementation

### 6.1 Overview

As previously said, the implementation of the several systems can not be made for one system all at once. To perform the best integration in an easier way, the assembly must be a parallel sequence iterating between systems.

Beginning with the manufacture of the MDF profiles and assembly of the structural monitor support, that will bring some minor problems that need to be solved namely: alignment errors and structural failures due to manufacture failures. As the CAD model is only a reference for the GCS concept, in reality, there will be divergences. That will require extra time and extra engineering solutions to guarantee that the project is delivered as close it can be from the concept and most of all, that fulfill all the requirements of reliability, robustness and of operations.

Furthermore, the wiring and cable management quantities and positions were initially conceived as an approximation, therefore resulting one more time in divergences of what was initially thought, meaning that as the assembly goes further, adaptability and flexibility is important.

### 6.2 Structure

As the Aerospace laboratory has a CNC machine, and the use of MDF was evidently a solution for this purpose, the possibilities were many. After some drafts, the final design was done. As the profiles were being manufactured, Fig.6.1(a) by the CNC, constant motorization was required since the CNC is a little bit old and their fixation screws are not in its best state. The fact that this CNC is not the best precision tool, the profiles were not finished yet. After that they were polished either with a drummel tool or with a wood sandpaper, Fig.6.1(c).

As the manufacture process was a very time consuming and the quality of the profiles were not the best due to the CNC machine being old, other solutions were found, namely FabLab Lisboa.

There is a place in Lisbon, about fifteen minutes from IST, called FabLab where every citizen can go there and benefit from the machines they have there. One of them is a two by one and half meter

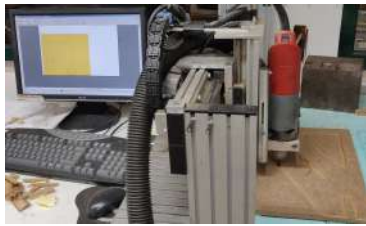

(a) CNC and desktop computer



(b) Central panel bottom cutting



(c) Top profile before polishing



(d) Profiles after being polished



(e) Two profiles being glued together



(f) Profiles drying after being glued

Figure 6.1: IST laboratory CNC machine manufacturing

CNC machine. It performs steps of 5mm in the Z axis while the CNC from the lab does 1mm step. This means that for a ten millimeter MDF plank the time required in the CNC from the lab would be about forty minutes per piece while in the FabLab's would be less than ten minute per piece. Not only better in time, but also in precision. The quality of the profiles were better in FabLab's CNC.

In order to tell the CNC machine what to manufacture, it is required to save the MDF profile in DXF format. That is done through the Solidworks CAD software. After that, depending on the CNC, there is a special software which translate the drawing into a series of coordinates that can be interpreted by the CNC. The FabLab's software once more proved to be more intuitive and easier to use. The possibilities were many. For instance, it can be specified if the drill goes inside, outside or outside of the line thus, not being necessary to perform two cuts in order to manufacture a closed profile.

After being manufactured and polished the profiles were glued together , Fig.6.1(e) and Fig.6.1(f).



(a) Central panel top



(b) Central panel top



(c) FabLab's CNC

Figure 6.2: FabLab Lisboa CNC machine manufacturing

At this point all the parts were manufactured and were ready for the assembly inside the station. The structure was pre assembled outside and then brought inside. The alignment was from left to

right, making sure that each part was well fixed with screws and "L" shaped metal plates. After that the technical gutter was fixed along with one CEE.



Figure 6.3: MDF structure and electric board panel fixation

### 6.3 Electrical

The electrical board panel was fixed in the first place. The technical gutters all across the area were conceived for the wiring placement, Fig.6.3(b). Most of the wiring was done at this time. Every time a new connection was done, a subsequently test was performed right after. This was a good way to know that the thing were running as supposed.

The double converter was connected to the station. This enabled the possibility of having the LED lights as well connected and their respective intensity regulators. For safety reasons, this required the fixation of the battery connectors. The short circuit risk was minimized by screwing them to the plastic technical gutter. With this all the 12VDC wires were connected, Fig.6.4(b).

The central indicator and control panel, that was previously assembled with all those switches and LED indicators, is also connected to the station and tested right after, Fig.6.4(c).

At this time two of the monitors have been fixed along with their respective wiring connections. The fixation was done using a standard LCD screen holder with two screws on one of the diagonal planks.



Figure 6.4: Wiring of some of the 230VAC and 12VDC grids

In addition, a small hatch was done in the existent wooden frame as it can be seen at the center in Fig.6.4(c).

### 6.3.1 Electrical Board and central Panels

In Fig.6.5 it is possible to see three of the principal human interfaces on this GCS.

Taking a closer look at the electrical board panel, Fig.6.5(a) shows both residual current devices on the left. At the center is the source selector. And finally, at the right just two simple 16A switches for the NONESSENTIALS@230 and ESSENTIALS@230, respectively.

In Fig.6.5(b) is the video system. Both video receivers, the FPV monitor and the SD card recorder. Passed on the testing, the implementation proceeds. The central indicator and control panel Fig.6.5(c) also performs its tasks.



(a) Electric board panel



(b) Top panel – Video system



(c) Central indicator and control panel

Figure 6.5: Electrical Board and central Panels

### 6.4 Final Assembly and Basic Testing

With everything working and running, some tests were performed on spot.



Figure 6.6: GCS running

The video stream was tested. The images appeared to be clear as it can be seen in Fig.6.5(b). For the MAVLINK connection, there was a similar test. With a pixhawk and the radios 3DR Robotics a flight was simulated. By opening the Mission Planner on the desktop computer, the connection was done in less than one minute and ran smoothly during all the time. The video stream kept running and recorded in the SD card during this time. In Fig.6.6 it is possible to see the GCS running with the Mission Planner opened on the top left screen.

For the PPM there was no test performed.



Figure 6.7: GCS with the assembled antennas

In Fig.6.7 the GCS and the antennas on top can be seen. Since the testing was performed inside the LAB, these antennas were positioned, but not used for these tests. These antennas are recommended for long range missions only.

# Chapter 7

## Conclusions

### 7.1 Achievements

A fully operational and versatile GCS for long range and Long endurance UAVs was assembled.

This GCS has numerous strengths. The fact that it can be running about eight hours with the insurance that it will never run out of energy during operations is a key aspect in any UAS operation.

In addition, the fact of being a mobile GCS gives it another plus. As the mission can be anywhere, this creates possibilities that other ground stations will not have. The fact, that there is enough space for at least three persons inside, is very useful too. This way, during an unexpected mission, the setup is very easy and fast with a crew of five. While two people – mechanic and the pilot – have to put the UAV on the air manually, there are two GCS's operators setting up the systems and the leader plans the mission, both inside the station. Once the UAV is airborne the main operator assumes control of the aircraft and starts sending it commands through mission planner.

Finally, many concepts were learned by implementing this work. Many soft and hard skills too. During research, a general idea for the working principle of UAS was formed. Taking requirements, transform them into design, assemble and test them is the art of system engineering which was applied here in this work too.

Now this GCS can have multiple applications for either the projects such like LEEUAV or any other project such like underwater vehicles, ground vehicles or even a rocket GCS.

The main innovative idea in this work was the design of the support 5.4. It gives a clean "v" shaped format, giving the possibility to fix the LCD screens with a desired angle and distance from the surface. Also giving the comfort of clean space in the outside while racking all the wires and supports on the inside.

### 7.2 Future Work

The station has lots of free space and was designed to keep being augmented. More electronic systems can be added, as well as new structures for object fixation. During a road trip to the mission

place, every object shall be well fixed to prevent material damage. Furthermore, the existent wooden frame can serve as a space for storage.

The operators seats can be easily improved by a sports car seat which fulfills the ergonomics requirements as well as looking cool.

Regarding the antenas, a better and easier setup solution could be envisioned.



# Bibliography

- [1] T. J. Q. J. T. K. Ping, A. E. Ling and C. Dat. Generic unmanned aerial vehicle (UAV) for civilian application. *IEEE Conference on Sustainable Utilization and Development in Engineering and Technology*, October 2012.
- [2] A. T. S. E. Charlie Hume Product Line Sales Engineer. Transfer switch 101 an introductory guide to picking the right transfer switch for your environment. <https://www.eaton.com/content/dam/eaton/products/low-voltage-power-distribution-controls-systems/ats/wp140001en.pdf>, March 2015.
- [3] U. Airspace. Drone delivery operations underway in 27 countries. <https://www.unmannedairspace.info/latest-news-and-information/drone-delivery-operations-underway-in-26-countries/>, April 2019.
- [4] Observador. Marinha quer embarcar primeiro destacamento de drones aéreos ainda este ano. <https://observador.pt/2019/09/20/marinha-quer-embarcar-primeiro-destacamento-de-drones-aereos-ainda-este-ano/>, Setember 2019.
- [5] P. de Oliveira Martins Gersão Miller. Design of a remote person view system for a long range uav. Master's thesis, Instituto Superior Técnico(IST), June 2015.
- [6] T. A. J. Frederik S. Leira, Håkon Hagen Helgesen and T. I. Fossen. Object detection, recognition, and tracking from UAVs using a thermal camera. *Wiley*, December 2019.
- [7] A. Guillen-Perez, R. Sanchez-Iborra, J. Sanchez-Aarnoutse, M.-D. Cano, and J. Garcia-Haro. Wifi networks on drones. 11 2016.
- [8] A. H. Kelechi, M. H. Alsharif, D. A. Oluwole, P. Achimugu, O. Ubadike, J. Nebhen, A. Aaron-Anthony, and P. Uthansakul. The recent advancement in unmanned aerial vehicle tracking antenna: A review. *Sensors*, 21(16), 2021. ISSN 1424-8220. doi: 10.3390/s21165662. URL <https://www.mdpi.com/1424-8220/21/16/5662>.
- [9] A. S. Rodrigues. Airframe assembly, systems integration and flight testing of a long endurance electric UAV. Master's thesis, Universidade da Beira Interior (UBI), February 2017.

- [10] L. Cândido. Projeto de um uav solar de grande autonomia. Master's thesis, Universidade da Beira Interior(UBI), 2014.
- [11] J. Sousa. Solar system for a long endurance electric uav. Master's thesis, Universidade da Beira Interior(UBI), 2015.
- [12] A. Duarte. Development part of the structure of a long endurance electric UAV. Master's thesis, Universidade da Beira Interior(UBI), 2016.
- [13] L. Freitas. Aerodynamic analysis of a forward-backward facing step pair on the upper surface of a low-speed airfoil. Master's thesis, Universidade da Beira Interior(UBI), 2017.
- [14] P. Moutinho. Real-time estimation of remaining flight time based on the total energy balance for UAV's. Master's thesis, Universidade da Beira Interior(UBI), 2017.
- [15] R. Altawy. Security, privacy, and safety aspects of civilian drones: A survey. *ACM Transactions on Cyber-Physical Systems*, 1:1–25, 11 2016. doi: 10.1145/3001836.
- [16] EASA. Commission implementing regulation (eu) 2019/947 of 24 may 2019 on the rules and procedures for the operation of unmanned aircraft. *Official Journal of the European Union*, June 2019.
- [17] H. Eisenbeiss et al. A mini unmanned aerial vehicle (UAV): system overview and image acquisition. *International Archives of Photogrammetry. Remote Sensing and Spatial Information Sciences*, 36 (5/W1):1–7, 2004.
- [18] G. Cai, J. M. M. Dias, and L. D. Seneviratne. A survey of small-scale unmanned aerial vehicles: Recent advances and future development trends. 2014.
- [19] ANAC. Registo de operador de aeronaves não tripuladas (uas - drones). [https://www.anac.pt/vPT/Generico/drones/registo\\_uas/Paginas/OperadoresdeUAS.aspx](https://www.anac.pt/vPT/Generico/drones/registo_uas/Paginas/OperadoresdeUAS.aspx), January 2021.
- [20] J. Brown. Types of military drones: The best technology available today. <https://www.mydronelab.com/blog/types-of-military-drones.html>, 2016.
- [21] T. Alladi, V. Chamola, N. Sahu, and M. Guizani. Applications of blockchain in unmanned aerial vehicles: A review. *Vehicular Communications*, 23:100249, 2020. doi: 10.1016/j.vehcom.2020.100249.
- [22] H. Shakhathreh, A. Sawalmeh, A. Al-Fuqaha, Z. Dou, E. Almaita, I. Khalil, N. Othman, A. Khreishah, and M. Guizani. Unmanned aerial vehicles (UAVs): A survey on civil applications and key research challenges, 04 2018.
- [23] T. B. R. Company. Aerospace global market report 2021: Covid-19 impact and recovery to 2030. [https://www.researchandmarkets.com/reports/5240238/aerospace-global-market-report-2021-covid-19?utm\\_source=GNOM&utm\\_medium=PressRelease&utm\\_code=z1749j&utm\\_campaign=1586062+-+Global+Aerospace+Market+](https://www.researchandmarkets.com/reports/5240238/aerospace-global-market-report-2021-covid-19?utm_source=GNOM&utm_medium=PressRelease&utm_code=z1749j&utm_campaign=1586062+-+Global+Aerospace+Market+)

Outlook+2021-2030%3a+Growing+Demand+for+Commercial+Use+of+Drones%2c+Emerging+Economies+and+Rapid+Technological+Advances&utm\_exec=cari18prd, January 2021.

- [24] D. Z. für Luft-und Raumfahrt German Aerospace Center. Super-efficient wings take off. [https://www.dlr.de/content/en/articles/news/2019/04/20191119\\_super-efficient-wings-take-off.html](https://www.dlr.de/content/en/articles/news/2019/04/20191119_super-efficient-wings-take-off.html), November 2019.
- [25] G. A. Aeronautical. Certifiable ground control station (cgcs). <https://www.ga-asi.com/ground-control-stations/certifiable-ground-control-station>, 2021.
- [26] DesetRotor. Dual screen uav ground station 12pcx hotas hd portable gcs. <https://desertrotor.com/product/12pcx-hotas-hd/>.
- [27] S. NEWS. Ga-asi's certifiable ground control station makes its first flight. <https://www.suasnews.com/2018/11/ga-asis-certifiable-ground-control-station-makes-its-first-flight/>, November 2018.
- [28] S. CUNNINGHAM. Uav's in the military. <https://sites.tufts.edu/eeniordesignhandbook/2015/uavs-in-the-military/>, 2015.
- [29] A. K. KHAN. Ground control station, functional requirements. <https://khandronesorigin.com/2016/11/23/ground-control-station-functional-requirements/>, 2016.
- [30] U. Technologies. Things to consider before purchasing a ground control station. <https://www.uvxtechnologies.com/ground-control-stations/guide-to-choosing-a-ground-control-station-gcs/>, 2016.
- [31] M. Jovanovic and D. Starcevic. Software architecture for ground control station for unmanned aerial vehicle. In *Tenth International Conference on Computer Modeling and Simulation (uksim 2008)*, pages 284–288, 2008. doi: 10.1109/UKSIM.2008.12.
- [32] A. Koubâa, A. Allouch, M. Alajlan, Y. Javed, A. Belghith, and M. Khalgui. Micro air vehicle link (mavlink) in a nutshell: A survey. *IEEE Access*, 7:87658–87680, 2019. doi: 10.1109/ACCESS.2019.2924410.
- [33] Ardupilot. Choosing a ground control station. <https://ardupilot.org/plane/docs/common-choosing-a-ground-station.html>.
- [34] P. Techavijit, S. Chivapreecha, P. Sukchalerm, and N. Wongphuangfuthaworn. Suitable altitude for long-operated communication high altitude balloon with experimental flights. In *2016 8th International Conference on Knowledge and Smart Technology (KST)*, pages 169–174, 2016. doi: 10.1109/KST.2016.7440494.
- [35] OPENCV. Open source computer vision. <https://opencv.org/>.
- [36] A. Cormos, A. Gheorghiu, V. Stan, and I. Danaila. Use of tensorflow and opencv to detect vehicles. pages 1–4, 06 2020. doi: 10.1109/ECAI50035.2020.9223173.

- [37] N. Tijtgat, W. Van Ranst, B. Volckaert, T. Goedemé, and F. De Turck. Embedded real-time object detection for a uav warning system. pages 2110–2118, 10 2017. doi: 10.1109/ICCVW.2017.247.
- [38] C. Thunberg and A. Tvaryanas. Human-centered ground control station design: The predator/reaper approach. *AUVSI Unmanned Systems North America Conference 2008*, 1:395–409, 01 2008.
- [39] A. Tvaryanas. Human systems integration in remotely piloted aircraft operations. *Aviation, space, and environmental medicine*, 77:1278–82, 01 2007.
- [40] I. Žabińska, A. Kuboszek, E. Sujová, and J. Zitnansky. Ergonomic diagnosis of a computer workstation. *Multidisciplinary Aspects of Production Engineering*, 1:739–744, 09 2018. doi: 10.2478/mape-2018-0093.
- [41] I. Žabińska, A. Kuboszek, E. Sujová, and J. Zitnansky. Ergonomic diagnosis of a computer workstation. *Multidisciplinary Aspects of Production Engineering*, 1:739–744, 09 2018. doi: 10.2478/mape-2018-0093.
- [42] J. Hamkins. *Pulse Position Modulation*, volume 1, pages 492 – 508. 11 2011. ISBN 9781118256053. doi: 10.1002/9781118256053.ch32.
- [43] O. Pokorný. *Design of Quadcopter Control System with Visual Guidance*. PhD thesis, 06 2018.
- [44] L. E. Frenzel. Welcome to antennas 101. <https://www.electronicdesign.com/technologies/passives/article/21769333/electronic-design-welcome-to-antennas-101>.
- [45] ANACOM. Quadro nacional de autorizações de frequências - qnaf. [https://www.anacom.pt/streaming/QNAF2018vgrafica.pdf?contentId=1497661&field=ATTACHED\\_FILE/](https://www.anacom.pt/streaming/QNAF2018vgrafica.pdf?contentId=1497661&field=ATTACHED_FILE/), .
- [46] ANACOM. Qual é a potência máxima autorizada para uma rede de radiocomunicações privativa? <https://www.anacom.pt/render.jsp?contentId=917639>, .
- [47] SUNPOWER. C60 solar cell mono crystalline silicon. [http://wildplanetoffroad.com.au/wp-content/uploads/2016/10/C60\\_DEF\\_Cell\\_Datasheet.pdf](http://wildplanetoffroad.com.au/wp-content/uploads/2016/10/C60_DEF_Cell_Datasheet.pdf).
- [48] H. Keshan, J. Thornburg, and T. S. Ustun. Comparison of lead-acid and lithium ion batteries for stationary storage in off-grid energy systems. 01 2016.
- [49] M. Aamir, K. Kalwar, and S. Mekhilef. Review: Uninterruptible power supply (ups) system. *Renewable and Sustainable Energy Reviews*, 58, 05 2016.
- [50] A. Khamis, M. R. Ab Ghani, C. Gan, M. S. Mohd Aras, M. Rahim, and Z. Rizman. Design and analysis of diesel generator with battery storage for microgrid system. *Journal of Fundamental and Applied Sciences*, 10:1884–1895, 04 2018.
- [51] A. P. Technologies. Automatic transfer switch (ats) transition modes. <https://www.ascopower.com/us/en/resources/articles/automatic-transfer-switch.jsp>.

- [52] Pasternack. Rf friis transmission calculator formula. <https://www.pasternack.com/t-calculator-friis.aspx>, 2021.
- [53] R. P. Company. A430s10 base station yagi beam. <https://www.diamondantenna.net/a430s10.html>.
- [54] ASUS. Asus vp229he eye care monitor. <https://www.asus.com/displays-desktops/monitors/eye-care/vp229he/>.
- [55] Eleduino. 10.1inch high brigtness ground station hd fpv monitor. <http://www.eleduino.com/10-1inch-High-Brigtiness-Ground-Station-HD-FPV-Monitor-with-HDMI-VGA-Audio-Video-FPV101A-p10602.html>.
- [56] jCalcnet. Ac and dc voltage drop calculator asnzs 3008. <https://www.jcalc.net/voltage-drop-calculator-as3008>.



## **Appendix A**

# **System Schematics**

# POWER SUPPLY

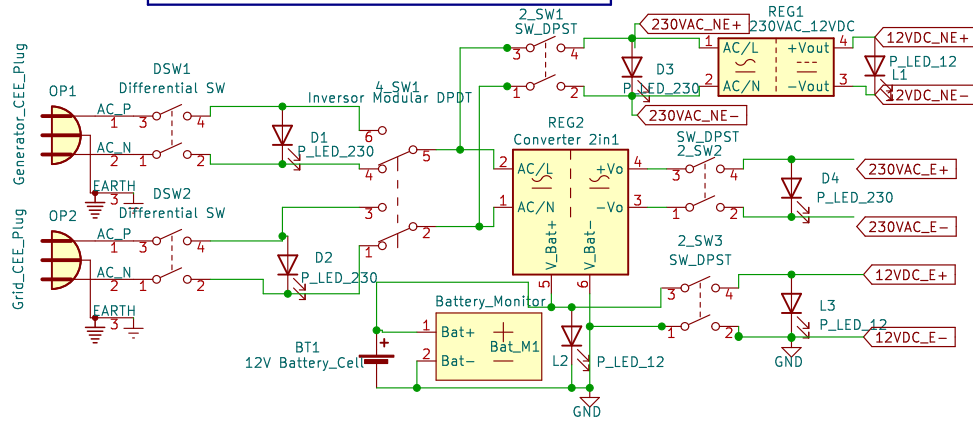

# Computer System

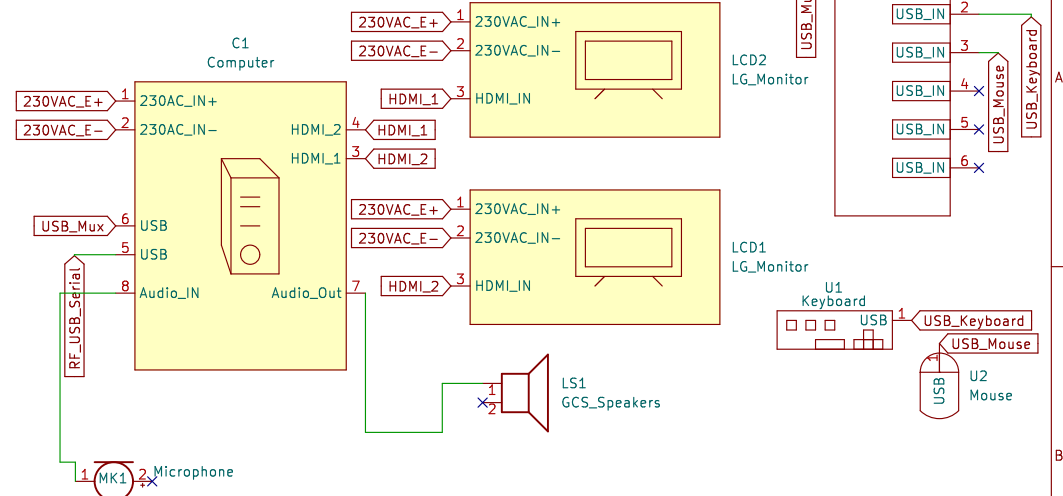

# VIDEO System

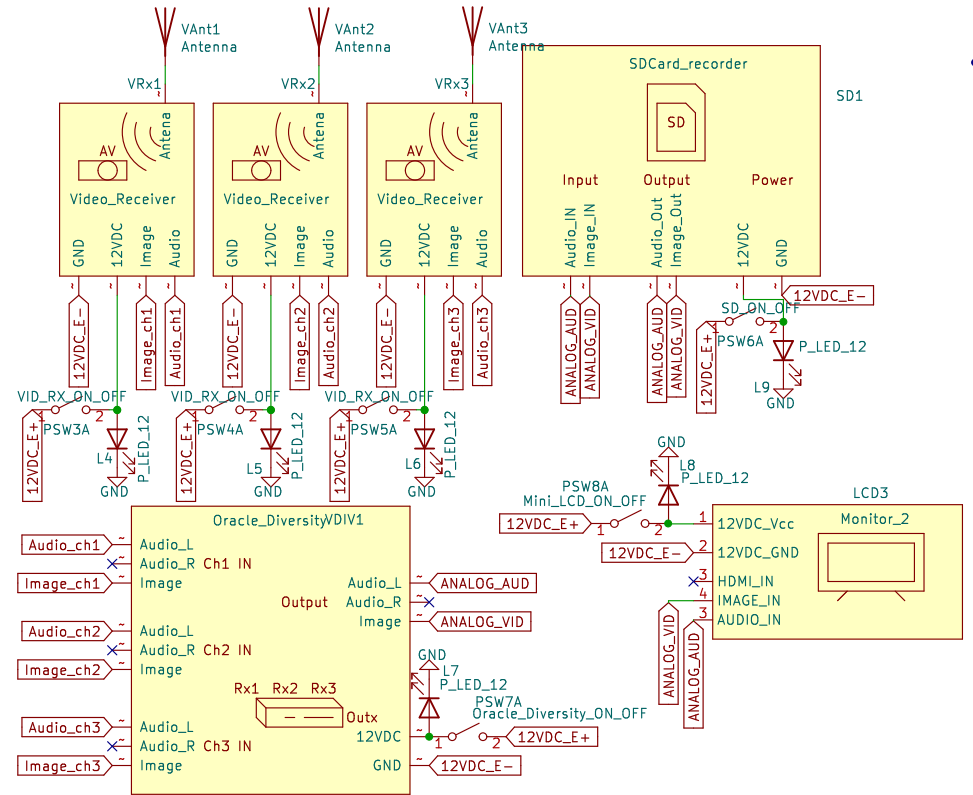

# Other

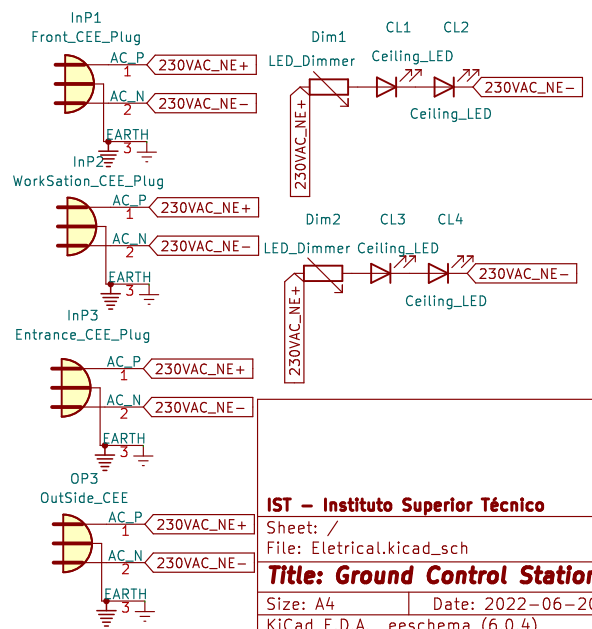

# Radio System

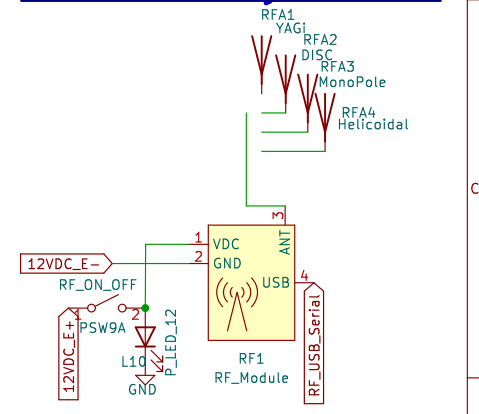





## **Appendix B**

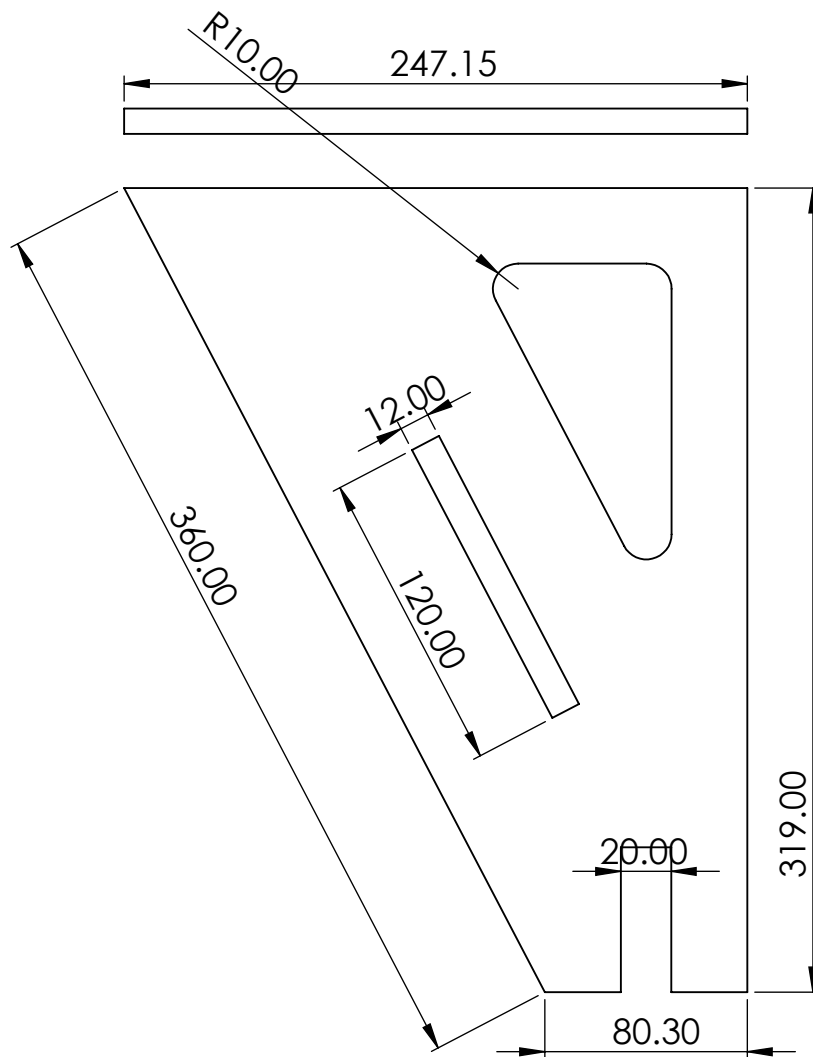

# **Technical Datasheets**

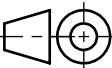
### **B.1 Structure Technical Drawings**

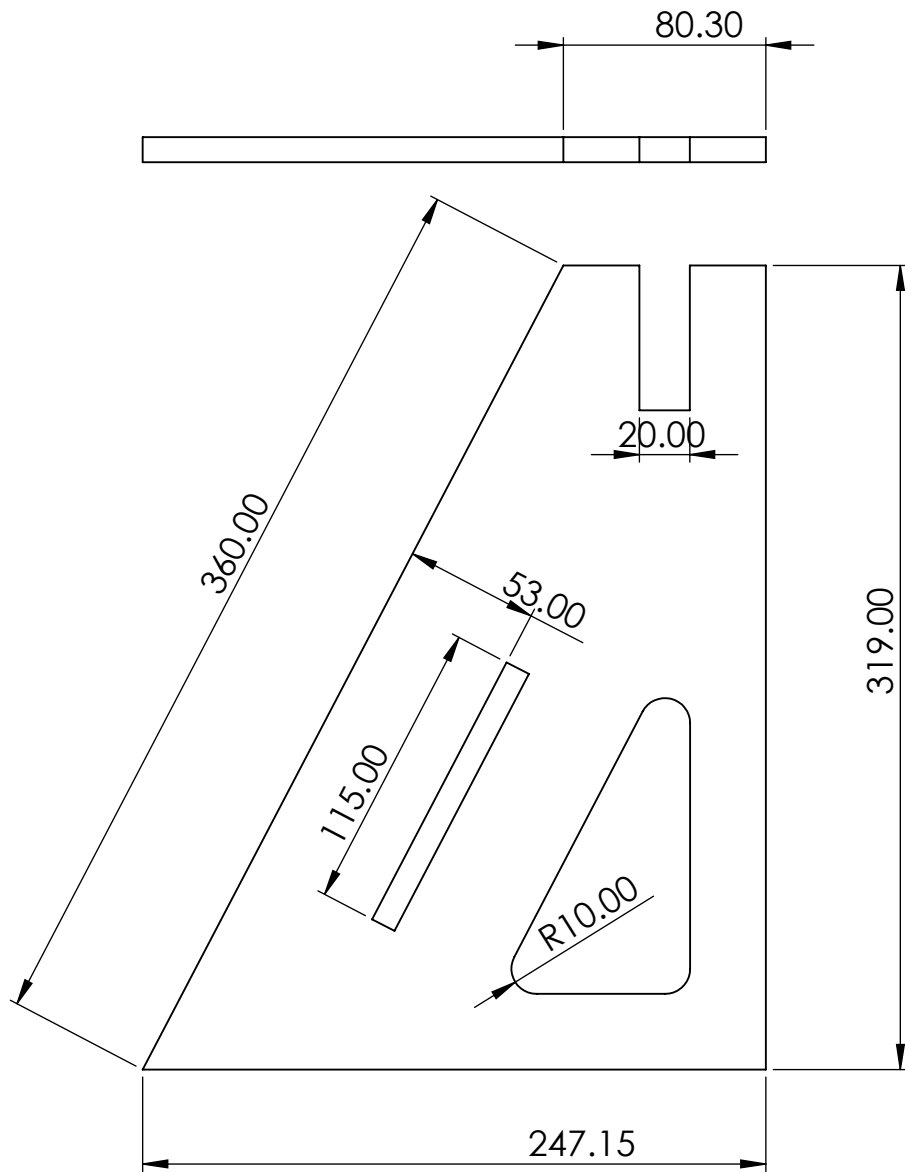

	Escala		Rúbrica	Data	GCS	
	1:5			10/29/2022		
Material: MDF			Desenhou		Nome: Nelson Cavaco	
			Verificou		Curso: MeAero	
Tolerância Geral:			Projectou		Perfil Baixo	
			Fabricou			
Acabamentos:			Notas:		Folha	Desenho n.º
					A4	M0XL01X-001
					Folha	Peso:
					1	Revisto:

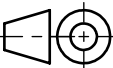

	Escala		Rúbrica	Data	GCS	
	1:3			10/29/2022		
Material: MDF			Desenhou		Nome: Nelson Cavaco	
			Verificou		Curso: MeAero	
Tolerância Geral:			Projectou		Perfil Cima	
			Fabricou			
Acabamentos:			Notas:		Folha	Desenho n.º
					A4	M0XL01X-001
					Folha	Peso:
					1	Revisto:

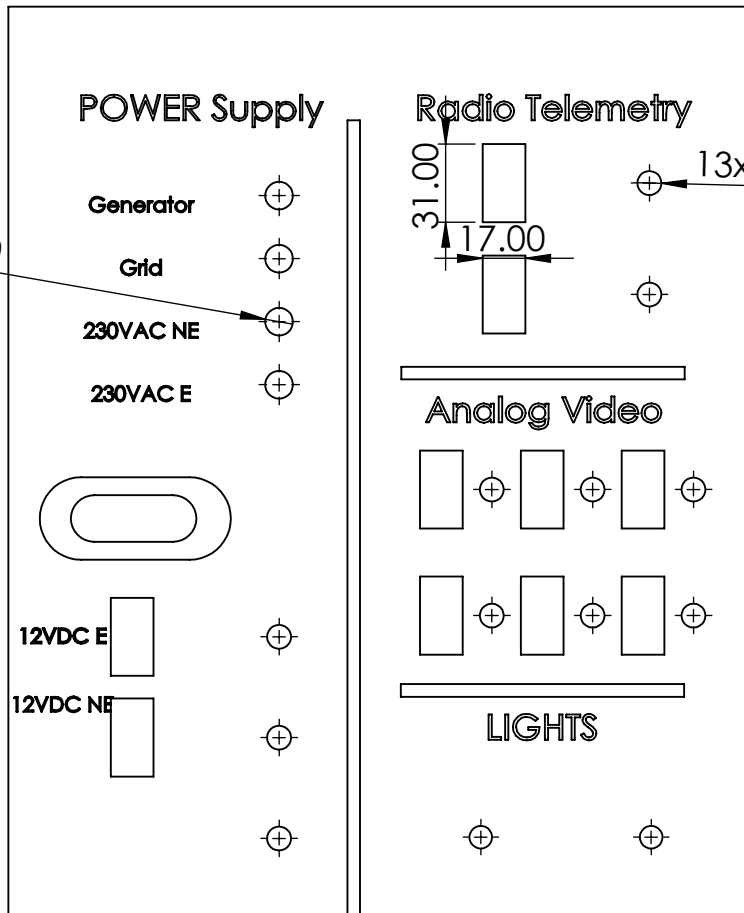
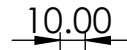
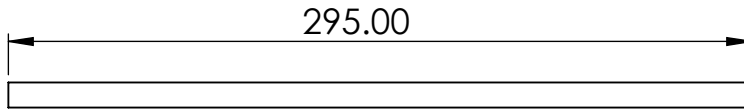

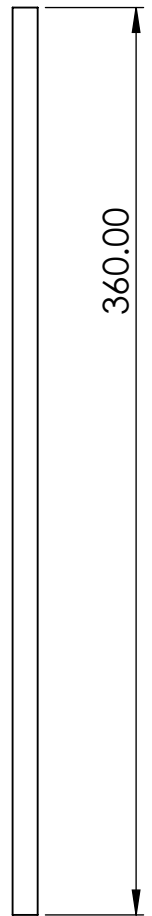
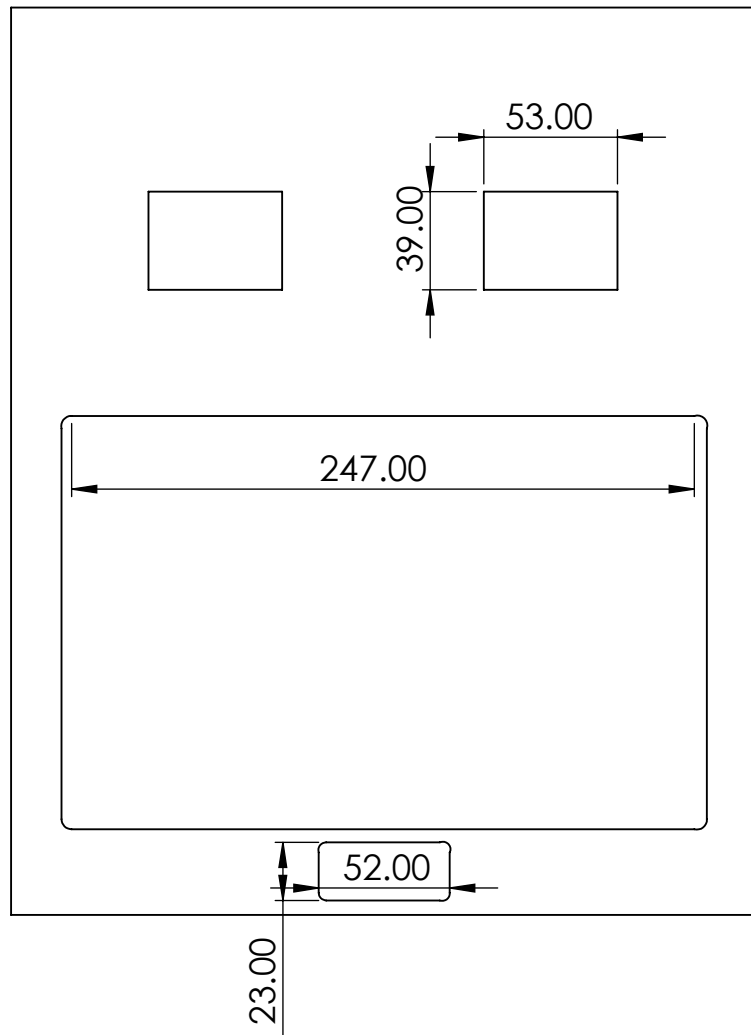
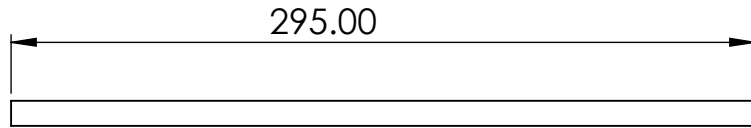

	Escala <b>1:3</b>	Rúbrica _____	Data 10/29/2022	<b>GCS</b>		
	Material: MDF	Desenhou _____	Verificou _____	Nome: Nelson Cavaco Curso: MeAero		
Tolerância Geral:	Notas:			<b>Central Panel Indicator</b>		
Acabamentos:	Folha <b>A4</b>	Desenho n.º M0XL01X-001	Folha <b>1</b>			

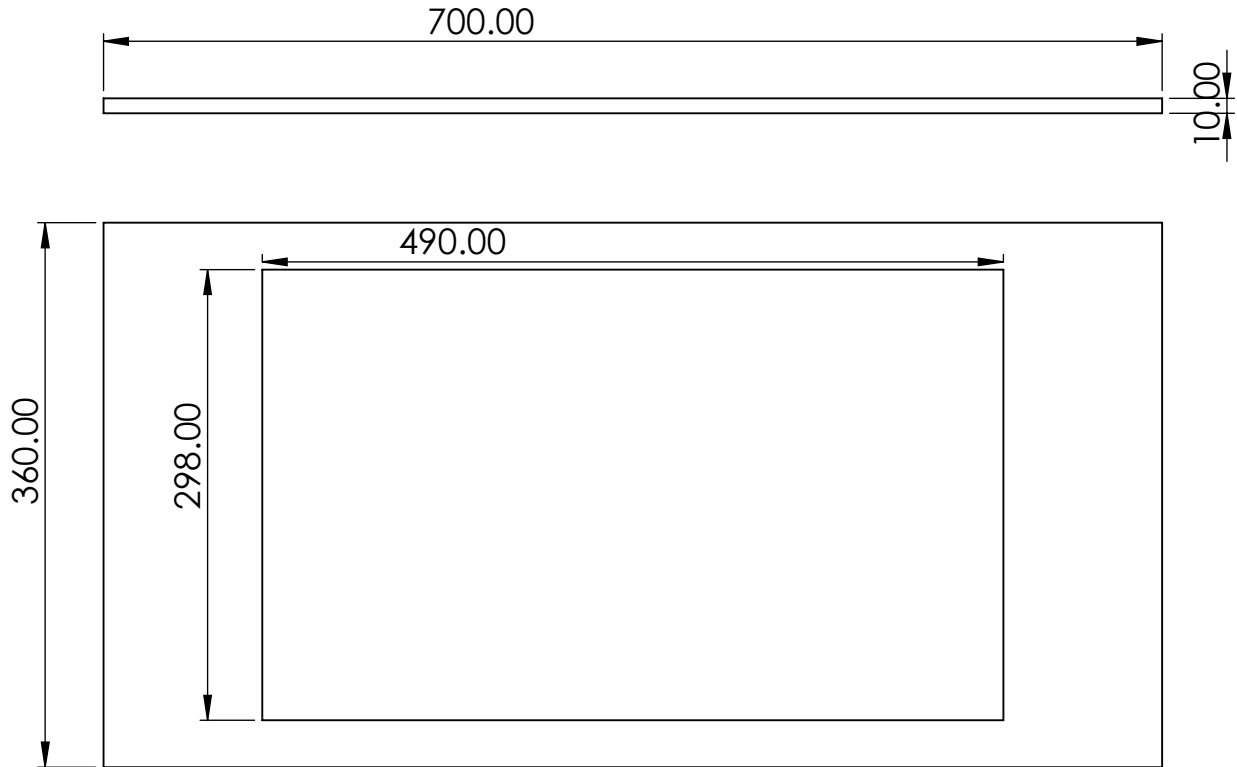

	Escala	Rúbrica	Data	GCS				
	1:3	Desenhou	10/29/2022	Nome: Nelson Cavaco				
Material: MDF	Verificou			Curso: MeAero				
Tolerância Geral:	Projectou			Central Panel Top				
Acabamentos:	Fabricou							
	Notas:			Folha	Desenho n.º	Folha	Peso:	Revisto:
				A4	M0XL01X-001	1		

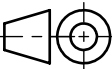

	Escala		Rúbrica	Data	GCS				
	1:5	Desenhou		10/29/2022					
Material: MDF		Verificou			Nome: Nelson Cavaco				
		Projectou			Curso: MeAero				
Tolerância Geral:		Fabricou			LCD Frame				
Acabamentos:		Notas:							
					Folha	Desenho n.º	Folha	Peso:	Revisto:
					A4	M0XL01X-001	1		